

SPUR GEAR PRODUCT LINE: CAST IRON PUMPS

SERIES SG-04, SG-05, SG-07, SG-10, SG-14

Section	1451
Page	1451.1
Issue	B

TABLE OF CONTENTS

Features & Benefits	2
Typical Applications.....	2
Port Location Options	2
Model Number Key	3
Standard Materials of Construction	3
Cutaway View & Pump Features	4
Component Identification (SG-04, SG-05 & SG-07).....	5
Component Identification (SG-10 & SG-14).....	5
Specifications	6
Mounting Options.....	7
Dimensions – SG-04 & SG-05 Series (Unmounted).....	8
Dimensions – SG-07 & SG-05 Series (Unmounted).....	9
Dimensions – SG-10 Series (Unmounted).....	10
Dimensions – SG-10 Series (Unmounted).....	10
Dimensions – SG-04 & SG-05 Series NEMA C-Flange (M Drive)	11
Dimensions – SG-07 Series NEMA C-Flange (M Drive).....	11
Dimensions – SG-10 Series NEMA (M Drive)	12
Dimensions – SG-14 Series NEMA (M Drive)	12
Dimensions – SG-04 & SG-05 Series IEC Frame (M Drive).....	13
Dimensions – SG-07 Series IEC Frame (M Drive).....	13
Dimensions – SG-10 Series IEC B35 Frame (M Drive)	14
Dimensions – SG-14 Series IEC B35 Frame (M Drive)	14
Dimensions – SG-04 & SG-05 Series 4-Bolt (M4 Drive)	15
Dimensions – SG-04 & SG-05 Series (B Drive).....	16
Dimensions – SG-07 Series (B Drive).....	16
Dimensions – SG-10 Series (B Drive).....	17
Dimensions – SG-14 Series (B Drive).....	17
Dimensions – SG-04 & SG-05 Series (D Drive).....	18
Dimensions – SG-07 Series (D Drive).....	18
NPSH Required	19

SERIES DESCRIPTION

Viking SG is an extensive series of precision, industrial-duty external gear pumps that develop higher pressures than other Viking pumps, yet offer a similarly broad range of options to handle a diverse range of liquids and applications.

With 26 different displacements in five frame sizes to 190 GPM (719 LPM), most applications can be closely matched to a pump operating at motor speeds, without the need for a reducer or gear motor.

These pumps were designed for greatest reliability, with standard features like spur-type gears (instead of helical gears, which thrust into pump casing and bracket) and rolling element anti-friction bearings (instead of bushings, which wear every time a pump is stopped and the hydrodynamic film is lost).

Unwanted leaks are prevented by using the best sealing technology available, including single or duplex lip seals, single mechanical component seals, and single or double mechanical cartridge seals with seal plans (SG-10 & SG-14 only).

Installation is simple, with brackets to close couple to NEMA or IEC motors, or foot mount for speed-reduced applications. Piping is easy, with straight-through, 180° ports with the industry's broadest variety of threaded ports and flange options.

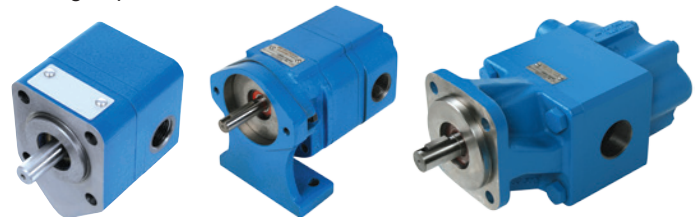

SG-0535

SG-0741 with
Footed B Drive Bracket

SG-1013

RELATED PRODUCTS

Cast Iron, Mag Drive Pumps: Catalog Section 1453

OPERATING RANGE

SERIES	NOMINAL FLOW		MAXIMUM PRESSURE*		TEMPERATURE RANGE		VISCOSITY RANGE	
	GPM	LPM	PSI	Bar	°F	°C	SSU	cSt
SG-04	0.06 - 0.50	0.23 - 1.89	500	34	-40 to +450	-40 to +230	28 to 1,000,000	1 to 250,000
SG-05	0.7 - 11.2	2.6 - 42.4	500	34	-40 to +450	-40 to +230	28 to 1,000,000	1 to 250,000
SG-07	2.8 - 32	10.6 - 121	500	34	-40 to +450	-40 to +230	28 to 1,000,000	1 to 250,000
SG-10	25 - 50	95 - 189	500	34	-40 to +450	-40 to +230	28 to 1,000,000	1 to 250,000
SG-14	70 - 190	265 - 719	500	34	-40 to +450	-40 to +230	28 to 1,000,000	1 to 250,000

* to 500 PSI (34 Bar) Continuous, to 2,500 PSI (170 Bar) Intermittent Pressure

Section	1451
Page	1451.2
Issue	B

**SPUR GEAR PRODUCT LINE:
CAST IRON PUMPS**
SERIES SG-04, SG-05, SG-07, SG-10, SG-14

FEATURES & BENEFITS

- Needle bearings provide high pressure capabilities, sleeve bearing options available
- Close-coupled motor mount or foot bracket options to match space or motor requirements

TYPICAL APPLICATIONS

- Fuels & Fuel Oils
- Lubricants
- Chemical Metering
- Solvents
- Alcohol
- Cooking Oils
- Paints, Inks & Coatings
- Polyurethanes
- Heat Transfer Fluids

PORT LOCATION OPTIONS

**Series SG-04, SG-05, SG-10 and SG-14 —
90° Positioning, “B” or “M” Drive**

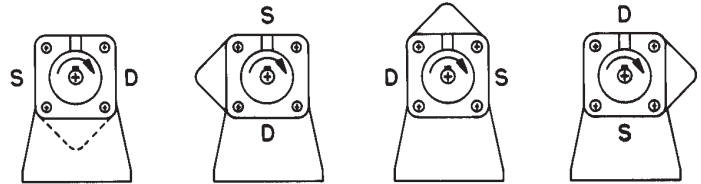

Pump can be mounted in any of four 90° positions, giving the option of horizontal or vertical porting. Arrow shows direction of motor rotation as clockwise, looking from shaft end. Ports are not on shaft centerline, so inverting will result in different port locations.

**Series SG-07 —
180° Positioning, “B” Drive**

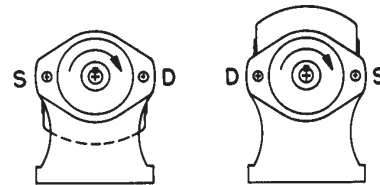

Clockwise pump can be mounted in either of two positions to obtain suction on right or left hand side. Offers 90° positioning with “M” drive. Ports are not on shaft centerline, so inverting will result in different port locations.

SPUR GEAR PRODUCT LINE: CAST IRON PUMPS

SERIES SG-04, SG-05, SG-07, SG-10, SG-14

Section	1451
Page	1451.3
Issue	B

MODEL NUMBER KEY

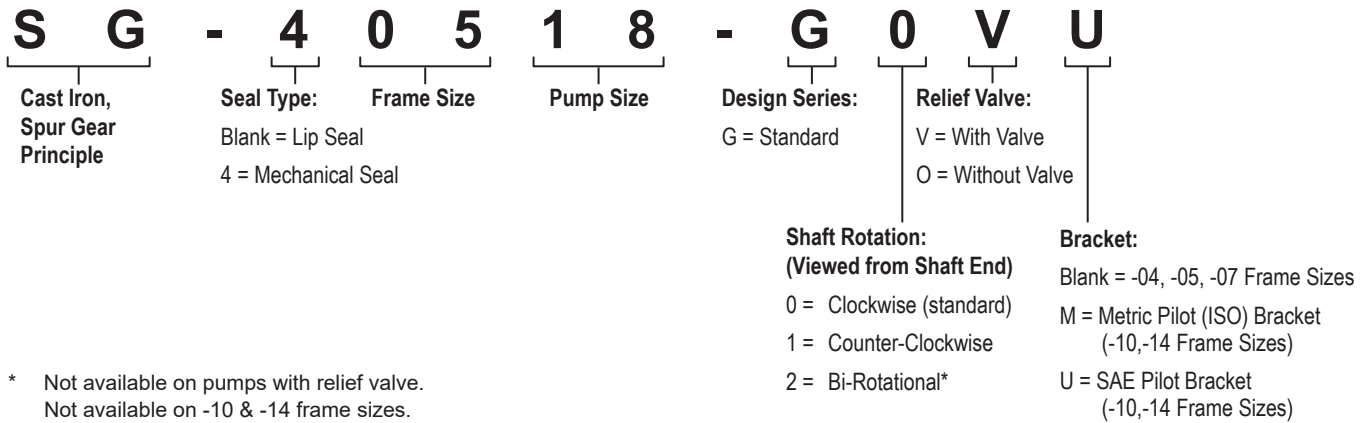

STANDARD MATERIALS OF CONSTRUCTION

Component	SG-04, -05, -07	SG-10, -14
Bracket	Cast Iron, ASTM A823	Cast Iron, ASTM A48
Casing	Cast Iron, ASTM A823	Ductile Iron, ASTM A536
Head, Separation Plate	Cast Iron, ASTM A823	Ductile Iron, ASTM A536
Relief Valve Body	Cast Iron, ASTM A823	Cast Iron, ASTM A48
Relief Valve Poppet	Hardened Steel	Ductile Iron, ASTM A536
Relief Valve Spring	Steel, ASTM A229	Chrome Silicon Spring Steel, ASTM A401
Gears	Heat Treated Steel	Heat Treated Steel
Shafts	Heat Treated Steel, ASTM A322	Heat Treated Steel, ASTM A322
Anti-Friction Needle Bearings ①	Bearing Steel	Bearing Steel
Journal Bearings	—	—
O-Rings	Viton®	Buna-N
Lip Seals	Viton®	Buna-N
Component Mechanical Seals	Carbon / Ni-Resist	Carbon / Silicon Carbide
Cartridge Mechanical Seals (Optional)	—	Cartridge seals are developed to order. Options include ISC (Flowserve) single or double seals in O-ring or metal bellows design, or John Crane single or double seals in rubber bellows, O-ring or metal bellows design. Other brands may be possible.
"B" Drive Foot Bracket	Cast Iron, ASTM A48	Cast Iron, ASTM A48
"M" Drive Motor Bracket	Cast Iron, ASTM A48	Aluminum

① Needle bearings standard with lip seals.

Viton™ is a trademark of The Chemours Company FC, LLC.

Section	1451
Page	1451.4
Issue	B

SPUR GEAR PRODUCT LINE: CAST IRON PUMPS

SERIES SG-04, SG-05, SG-07, SG-10, SG-14

CUTAWAY VIEW & PUMP FEATURES

Two section pump (casing and bracket) on SG-10 & -14 reduces runout to keep shaft aligned for long seal life. Three section pump (casing, bracket and head) on SG-04, -05 & -07 allows for more precise machining for closest clearances on low flows.

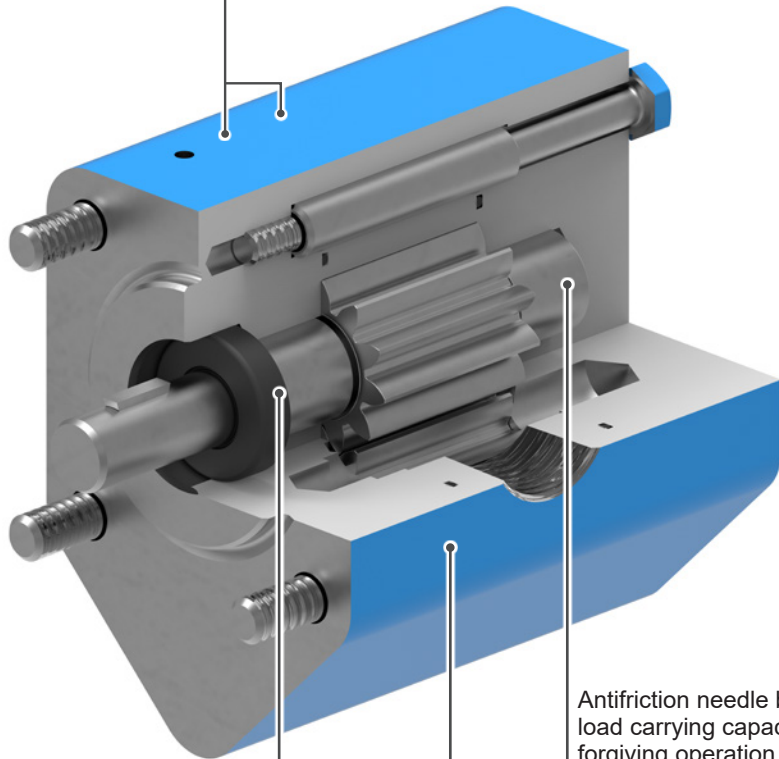

Sealing options include single lip seal, duplex lip seals with grease barrier, or single mechanical seal (all SG sizes). In addition, SG-10 and -14 offers pinned mechanical seal for high viscosity, and cartridge style single or double mechanical seals.

Antifriction needle bearings with high load carrying capacity standard for forgiving operation. Sleeve bearing options include carbon graphite for thin liquids, high temperature carbon, and silicon carbide for abrasives.

Hardened steel gears and shafts minimize wear. Spur-type gears minimize axial thrust for long seal life.

SPUR GEAR PRODUCT LINE: CAST IRON PUMPS

SERIES SG-04, SG-05, SG-07, SG-10, SG-14

Section	1451
Page	1451.5
Issue	B

COMPONENT IDENTIFICATION (SG-04, SG-05 & SG-07)

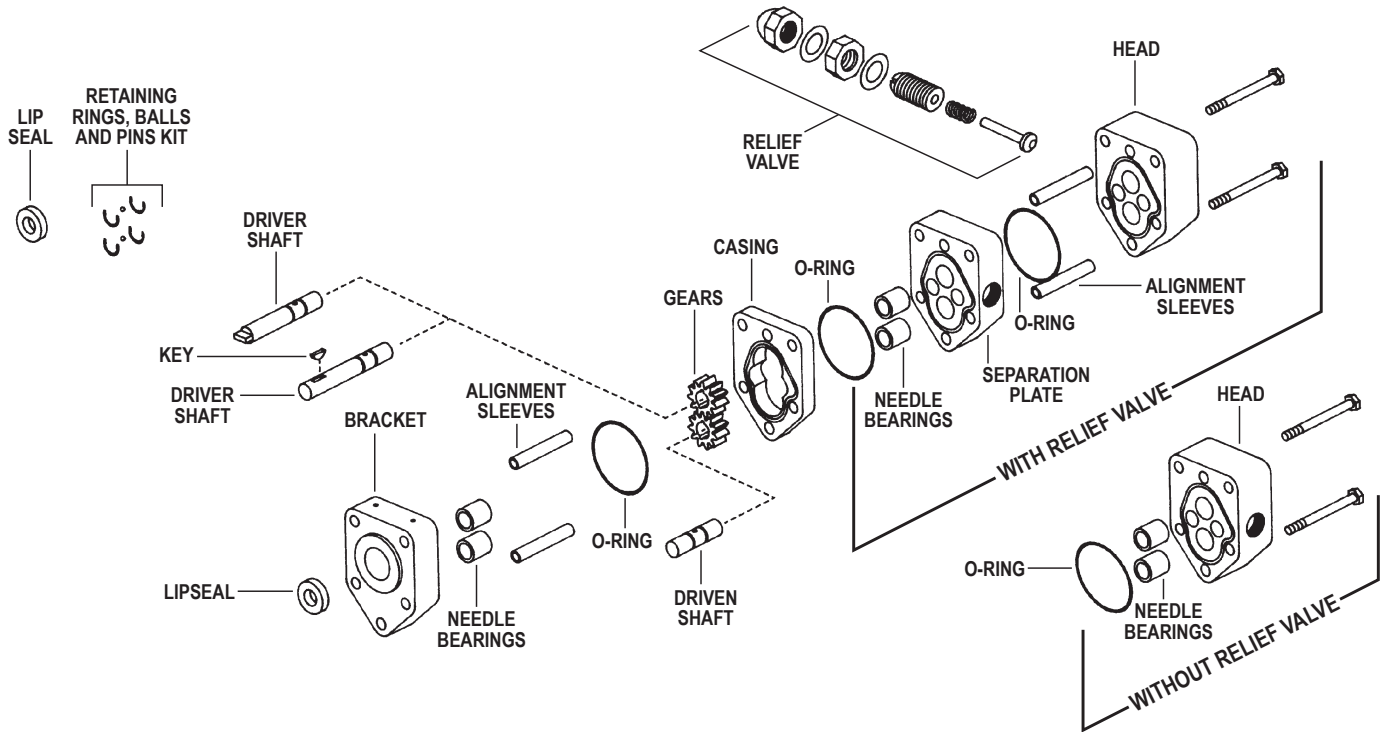

COMPONENT IDENTIFICATION (SG-10 & SG-14)

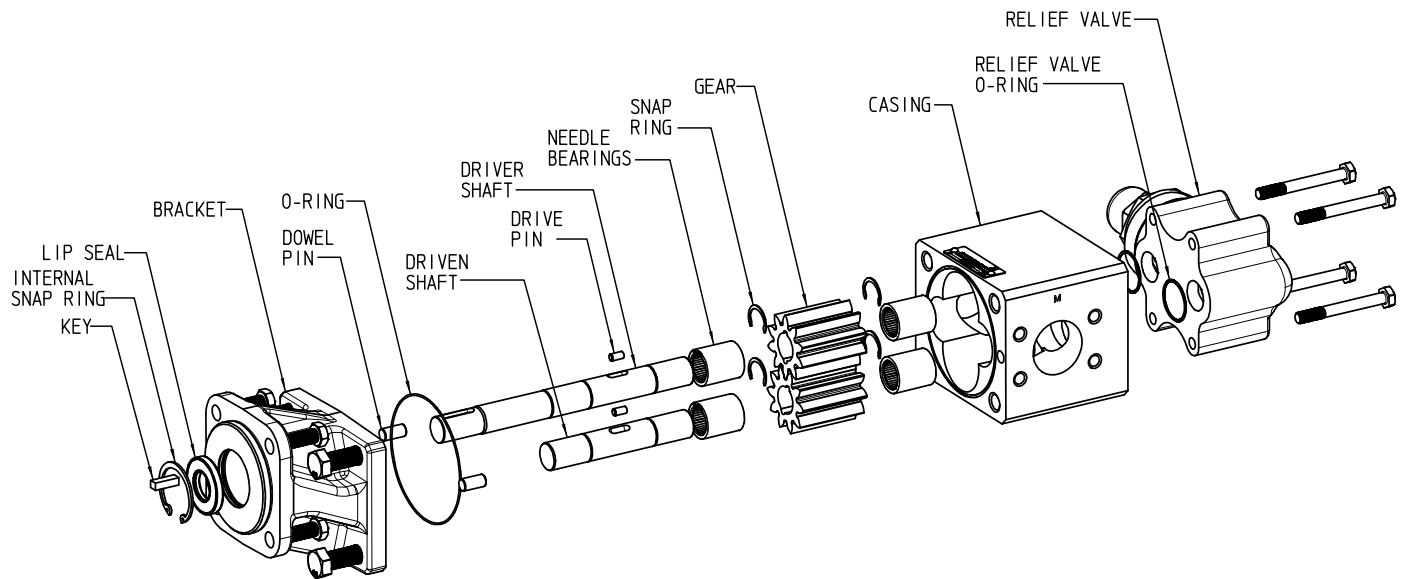

Section	1451
Page	1451.6
Issue	B

**SPUR GEAR PRODUCT LINE:
CAST IRON PUMPS**
SERIES SG-04, SG-05, SG-07, SG-10, SG-14

SPECIFICATIONS

③ Model Number		Port Size	⑥ Nominal Capacity at 50 Hz Motor Speeds (1450 RPM)		⑥ Nominal Capacity at 60 Hz Motor Speeds (1750 RPM)		④ Maximum Continuous Pressure		④ Maximum Intermittent Pressure		② Maximum Recommended Temperature for Standard Pump		Approximate Shipping Weight (Pump Only)	
			Inches	GPM	LPM	GPM	LPM	PSIG	BAR	PSIG	BAR	°F	°C	Lbs.
Lip Seal	① Mech. Seal													
SG-0417	SG-40417	3/8 ⑦	0.05	0.19	0.06	0.23	500	34	750	52	350	175	6	2.7
SG-0418	SG-40418	3/8 ⑦	0.12	0.44	0.14	0.53	500	34	1250	86	350	175	6	2.7
SG-0425	SG-40425	3/8 ⑦	0.15	0.56	0.18	0.68	500	34	1500	103	350	175	6	2.7
SG-0470	SG-40470	3/8 ⑦	0.41	1.57	0.5	1.89	500	34	1500	103	350	175	7	3.2
⑤ SG-0518	SG-40518	1/2 ⑦	0.58	2.2	0.7	2.6	500	34	1500	103	350	175	6	2.7
⑤ SG-0525	SG-40525	1/2 ⑦	0.83	3.1	1	3.8	500	34	2500	170	350	175	6	2.7
⑤ SG-0535	SG-40535	1/2 ⑦	1.16	4.4	1.4	5.3	500	34	2500	170	350	175	6	2.7
⑤ SG-0550	SG-40550	1/2 ⑦	1.66	6.3	2	7.6	500	34	2500	170	350	175	7	3.2
⑤ SG-0570	SG-40570	1/2 ⑦	2.32	8.8	2.8	10.6	500	34	1800	124	350	175	7	3.2
⑤ SG-0510	SG-40510	1/2 ⑦	3.31	12.5	4	15.1	500	34	1250	86	350	175	8	3.6
⑤ SG-0514	SG-40514	3/4 ⑦	4.64	17.6	5.6	21.2	500	34	900	62	350	175	9	4.1
⑤ SG-0519	SG-40519	3/4 ⑦	6.3	23.8	7.6	28.8	200	14	400	28	350	175	10	4.5
⑤ SG-0528	SG-40528	3/4 ⑦	9.28	35.1	11.2	42.4	100	7	200	14	350	175	11	5
SG-0729	SG-40729	1 ⑦	2.3	8.8	2.8	10.6	500	34	2500	170	350	175	14	6.4
SG-0741	SG-40741	1 ⑦	3.3	12.5	4	15.1	500	34	2500	170	350	175	15	6.8
SG-0758	SG-40758	1 ⑦	4.6	17.6	5.6	21.2	500	34	2500	170	350	175	17	7.7
SG-0782	SG-40782	1 ⑦	6.6	25.1	8	30.3	500	34	2250	155	350	175	18	8.2
SG-0711	SG-40711	1 ⑦	9.3	35.1	11.2	42.4	500	34	1600	110	350	175	19	8.6
SG-0716	SG-40716	1 ⑦	13	50	16	61	500	34	1100	76	350	175	20	9.1
SG-0722	SG-40722	1 1/2 x 1 1/4 ⑦	18	69	22	83	500	34	1600	110	350	175	41	18.6
SG-0732	SG-40732	1 1/2 x 1 1/4 ⑦	26	100	32	121	500	34	1100	76	350	175	43	19.5
SG-1013	SG-41013	1 1/2 ⑧	21	78	25	95	500	34	1900	130	225	105	49	22.1
SG-1026	SG-41026	2 ⑧	41	157	50	189	500	34	1000	68	225	105	54	24.5
SG-1420	SG-41420	2 ⑧	58	220	70	265	500	34	1100	75	225	105	130	59.1
SG-1436	SG-41436	3 ⑧	104	392	125	473	290	20	580	40	225	105	158	71.5
SG-1456	SG-41456	4 ⑧	158	597	190	719	190	13	380	26	225	105	189	85.8

① Carbon graphite bushings are standard when mechanical (face type) shaft seal option is specified. Needle bearings standard with lip seals.

② With optional sealing elements of PTFE or Kalrez®, temperatures up to +450°F (+230°C) are possible. Extra clearances may be required. Contact factory for recommendations.

③ See model numbering code, page 341.1.2.

④ For maximum recommended discharge pressures when handling other viscosities and/or operating at other speeds, visit the Viking Pump Curve Generator at www.vikingpump.com.

⑤ UL 343 rating (-X) for fuel oil is available on this pump.

⑥ Nominal capacity based on 100 SSU (22 cSt) liquid at 100 PSI (7 BAR)

⑦ NPT standard. Consult factory for other port size or type options such as BSP, SAE O-Ring or other.

⑧ SAE J518 Code 61 flange with metric threaded fastener holes standard.

Consult factory for other port sizes or type options such as NPT, BSP, SAE O-Ring or other.

NOTE: Adapter from SAE J518 Code 61 flange or tapped port to ANSI or DIN flange available from Viking.

Contact factory with desired flange face and length for quote.

Kalrez® is a registered trademark of E.I. du Pont de Nemours and Company.

SPUR GEAR PRODUCT LINE: CAST IRON PUMPS

SERIES SG-04, SG-05, SG-07, SG-10, SG-14

Section	1451
Page	1451.7
Issue	B

MOUNTING OPTIONS

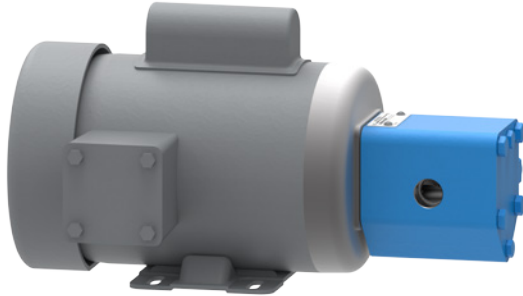

Four-Bolt Motor Mounted Units (M4 Drive)

Pump mounted directly to tang drive motor.

It helps reduce onsite assembly costs and provides maximum compactness where space is at a premium.

Series: SG-04, SG-05

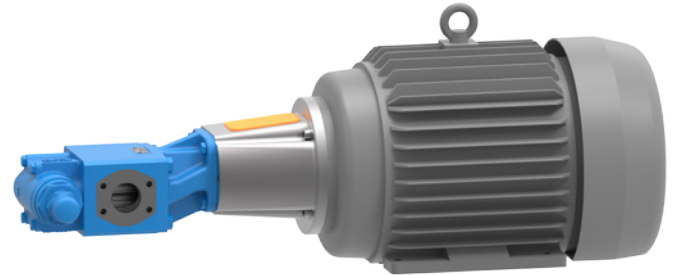

Motor Mounted Units (M Drive)

Pump and motor (NEMA or IEC) mounted to a flange mounting bracket with coupling.

This mounting arrangement eliminates the need for on-site coupling alignment that is normally required with a base mounted unit.

Series: SG-04, SG-05, SG-07, SG-10, SG-14

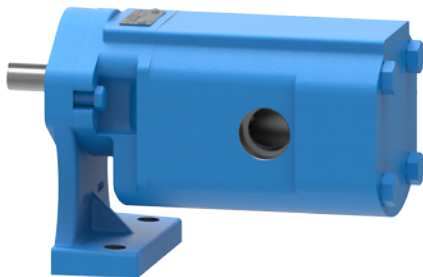

Foot Bracket Mounted Pumps (B Drive)

Pump is mounted to a foot bracket.

Foot bracket is machined by Viking for an accurate fit with the pump. B Drive is required for cartridge seals on SG-10 and SG-14. Outboard bearing required for side loads.

Series: SG-04, SG-05, SG-07, SG-10, SG-14

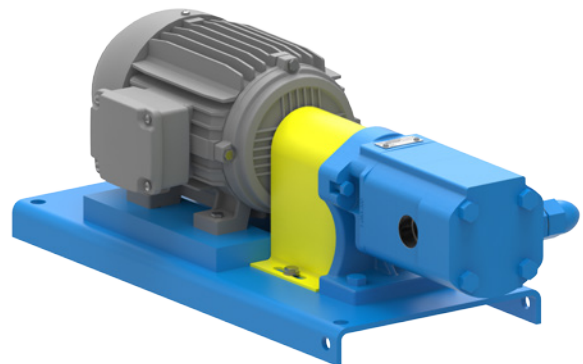

Base Mounted Direct Drive (D Drive)

Pump is direct connected to a on a base with coupling and coupling guard.

Rectangular, formed steel base provides a solid mounting for the drive equipment and the foot bracket mounted pump

Series: SG-04, SG-05, SG-07, SG-10, SG-14

Section	1451
Page	1451.8
Issue	B

**SPUR GEAR PRODUCT LINE:
CAST IRON PUMPS**
SERIES SG-04, SG-05, SG-07, SG-10, SG-14

DIMENSIONS – SG-04 & SG-05 SERIES (UNMOUNTED)

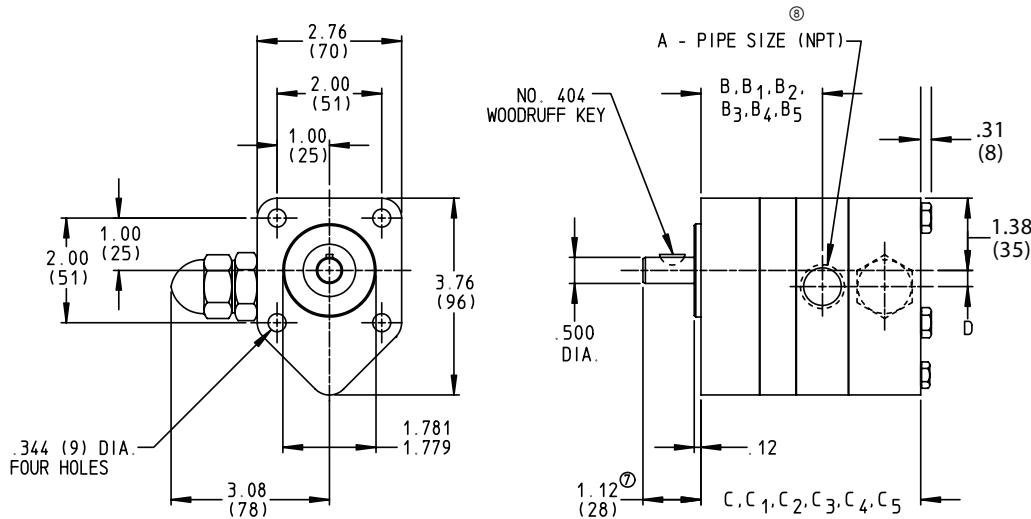

Model Number		A (in)	B	① B1	② B2	③ B3	④ B4	⑤ B5	C	① C1	② C2	③ C3	④ C4	⑤ C5	D
Lip Seal	Mechanical Seal														
SG-0417	SG-40417	3/8	in 1.8	2.68	2.18	1.99	2.87	2.37	3.68	4.56	4.06	2.68	3.56	3.06	0.31
		mm 46	68	55	51	73	60	93	116	103	68	90	78	8	
SG-0418	SG-40418	3/8	in 1.8	2.68	2.18	1.99	2.87	2.37	3.68	4.56	4.06	2.68	3.56	3.06	0.31
		mm 46	68	55	51	73	60	93	116	103	68	90	78	8	
SG-0425	SG-40425	3/8	in 1.87	2.75	2.25	2.06	2.94	2.44	3.75	4.63	4.13	2.75	3.63	3.13	0.31
		mm 47	70	57	52	75	62	95	118	105	70	92	80	8	
SG-0470	SG-40470	3/8	in 2.32	3.2	2.7	2.51	3.39	2.89	4.2	5.08	4.58	3.2	4.08	3.58	0.31
		mm 59	81	69	64	86	73	107	129	116	81	104	91	8	
SG-0518	SG-40518	1/2	in 1.8	2.68	2.18	1.99	2.87	2.37	3.68	4.56	4.06	2.68	3.56	3.06	0.31
		mm 46	68	55	51	73	60	93	116	103	68	90	78	8	
SG-0525	SG-40525	1/2	in 1.87	2.75	2.25	2.06	2.94	2.44	3.75	4.63	4.13	2.75	3.63	3.13	0.31
		mm 47	70	57	52	75	62	95	118	105	70	92	80	8	
SG-0535	SG-40535	1/2	in 1.97	2.85	2.35	2.16	3.04	2.54	3.85	4.73	4.23	2.85	3.73	3.23	0.31
		mm 50	72	60	55	77	65	98	120	107	72	95	82	8	
SG-0550	SG-40550	1/2	in 2.12	3	2.5	2.31	3.19	2.69	4	4.88	4.38	3	3.88	3.38	0.31
		mm 54	76	64	58	81	68	102	124	111	76	99	86	8	
SG-0570	SG-40570	1/2	in 2.32	3.2	2.7	2.51	3.39	2.89	4.2	5.08	4.58	3.2	4.08	3.58	0.31
		mm 59	81	69	64	86	73	107	129	116	81	104	91	8	
Ⓞ SG-0510	Ⓞ SG-40510	1/2	in 1.62	2.5	2	1.62	2.5	2	4.5	5.38	4.88	3.5	4.38	3.88	0.31
			mm 41	64	51	41	64	51	114	137	124	89	111	99	8
Ⓞ SG-0514	Ⓞ SG-40514	3/4	in 1.82	2.7	2.2	1.82	2.7	2.2	4.9	5.78	5.28	3.9	4.78	4.28	0.19
		mm 46	69	56	46	69	56	124	147	134	99	121	109	5	
Ⓞ SG-0519	Ⓞ SG-40519	3/4	in 2.07	2.95	2.45	2.07	2.95	2.45	5.4	6.28	5.78	4.4	5.28	4.78	0.19
		mm 53	75	62	53	75	62	137	160	147	112	134	121	5	
Ⓞ SG-0528	Ⓞ SG-40528	3/4	in 1.82	2.7	2.2	1.82	2.7	2.2	6.3	7.18	6.68	5.3	6.18	5.68	0.19
		mm 46	69	56	46	69	56	160	182	170	135	157	144	5	

- ① These dimensions apply when the mechanical shaft seal option is selected.
- ② These dimensions apply when the overhung load option (outboard bearing) is selected.
- ③ These dimensions apply when the relief valve is deleted.
- ④ These dimensions apply when the relief valve is deleted and the mechanical shaft seal option is selected.
- ⑤ These dimensions apply when the relief valve is deleted and the overhung load option (outboard bearing) is selected.

Ⓞ These models have the ports in the casing. Others ported in separation plate.

Ⓡ When the overhung load option (outboard bearing) is selected the pump shaft extension becomes 1.62" (41mm).

Ⓢ Standard ports NPT. Optional threads include BSP and SAE O-ring J1453.

NOTE: Bracket Pilot USA 4F17 4-Bolt

These dimensions are average and not for construction purposes. Certified prints on request.

SPUR GEAR PRODUCT LINE: CAST IRON PUMPS

SERIES SG-04, SG-05, SG-07, SG-10, SG-14

Section	1451
Page	1451.9
Issue	B

DIMENSIONS – SG-07 & SG-05 SERIES (UNMOUNTED)

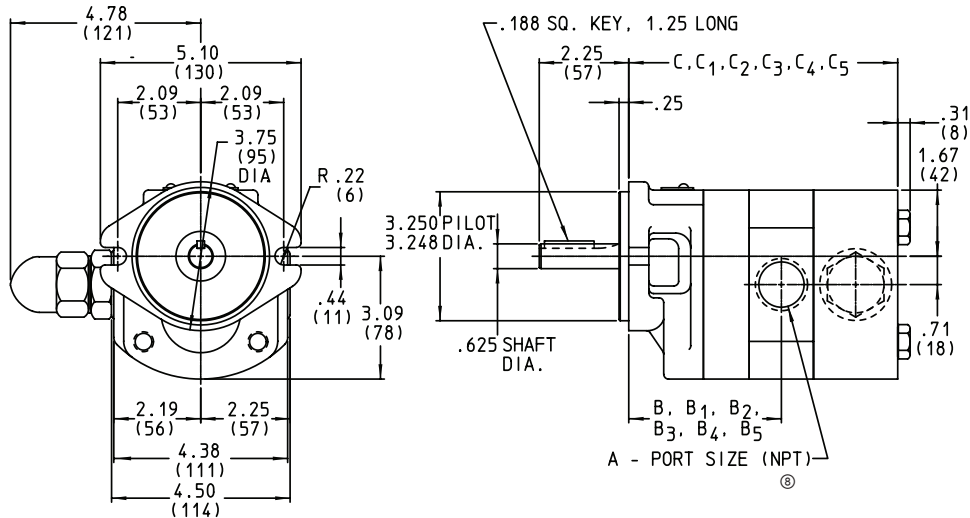

Model Number	A (in)		B	① B1	② B2	③ B3	④ B4	⑤ B5	C	① C1	② C2	③ C3	④ C4	⑤ C5
SG-0741	⑥ 1	in	3.10	4.72	3.29	4.91	3.54	5.16	6.03	7.65	4.41	6.03	6.91	8.53
		mm	79	120	84	125	90	131	153	194	112	153	176	217
SG-0758	⑥ 1	in	3.27	4.89	3.46	5.08	3.71	5.33	6.20	7.82	4.58	6.20	7.08	8.70
		mm	83	124	88	129	94	135	157	199	116	157	180	221
SG-0782	⑥ 1	in	3.51	5.13	3.70	5.32	3.95	5.57	6.44	8.06	4.82	6.44	7.32	8.94
		mm	89	130	94	135	100	141	164	205	122	164	186	227
SG-0711	⑥ 1	in	3.84	5.46	4.03	5.65	4.28	5.90	6.77	8.39	5.15	6.77	7.65	9.27
		mm	98	139	102	144	109	150	172	213	131	172	194	235
SG-0716	⑥ 1	in	4.34	5.96	4.53	6.15	4.78	6.40	7.27	8.89	5.65	7.27	8.15	9.77
		mm	110	151	115	156	121	163	185	226	144	185	207	248
SG-0722	⑦ 1½ x 1¼	in	4.28	5.90	4.28	5.90	—	—	10.42	12.04	8.80	10.42	—	—
		mm	109	150	109	150	—	—	265	306	224	265	—	—
SG-0732	⑦ 1½ x 1¼	in	4.78	6.40	4.78	6.40	—	—	11.42	13.04	9.80	11.42	—	—
		mm	121	163	121	163	—	—	290	331	249	290	—	—

- ① These dimensions apply when the mechanical shaft seal option is selected.
- ② These dimensions apply when the relief valve is deleted.
- ③ These dimensions apply when the relief valve is deleted and the mechanical shaft seal option is selected.
- ④ These dimensions apply when the oversize port option (1½" NPT suction, 1¼" NPT discharge) is selected, with or without the relief valve.
- ⑤ These dimensions apply when the oversize port option (1½" NPT suction, 1¼" NPT discharge) and the mechanical seal option are both selected, with or without the relief valve.
- ⑥ Standard ports for these size pumps are 1" NPT. Oversize ports are available (1½" NPT suction, 1¼" NPT discharge) as an option on clockwise rotation pumps only. See footnotes 4 and 5 for appropriate dimensions.
- ⑦ Standard ports for these size pumps are 1½" NPT suction, 1¼" NPT discharge. These pumps are only available in clockwise rotation.
- ⑧ Standard ports NPT. Optional threads include BSP and SAE O-ring J1453.

NOTE: SG-07 bracket to SAE-A 2-bolt standard for NEMA or IEC M-drive

These dimensions are average and not for construction purposes. Certified prints on request.

Section	1451
Page	1451.10
Issue	B

**SPUR GEAR PRODUCT LINE:
CAST IRON PUMPS**
SERIES SG-04, SG-05, SG-07, SG-10, SG-14

DIMENSIONS – SG-10 SERIES (UNMOUNTED)

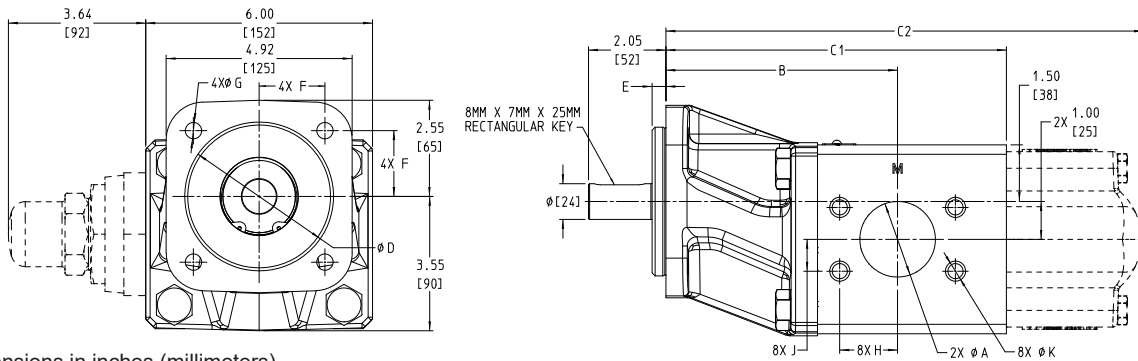

NOTE: Dimensions in inches (millimeters)

Model Number			A ③	B	C1	C2	D	E	F	G	H	J	K
SG-1013 ①	U	in	1.50	5.91	8.04	11.61	4.00	0.37	1.77	0.56	1.38	0.70	M12 X 1.75 X 19.5
SG-1013 ②	M	mm	38	150	204	295	100	9	44	11	35	18	M12 X 1.75 X 19.5
SG-1026 ①	U	in	2.00	6.13	9.01	12.58	4.00	0.37	1.77	0.56	1.53	0.84	M12 X 1.75 X 19.5
SG-1026 ②	M	mm	51	156	229	320	100	9	44	11	39	21	M12 X 1.75 X 19.5

- ① Bracket pilot SAE-B 4-bolt standard for NEMA M-drive or foot bracket
- ② Bracket pilot 100 mm ISO 3019-2 DIN 4x standard for IEC M-drive or foot bracket
- ③ Standard ports SAE J518 code 61 flange. Optional tapped ports on same centerline include NPT or BSP (up to 2") or SAE O-Ring J1453 (up to 2")
- ④ Bracket pilot SAE B 4-Bolt or 100 mm ISO 3019-2

DIMENSIONS – SG-10 SERIES (UNMOUNTED)

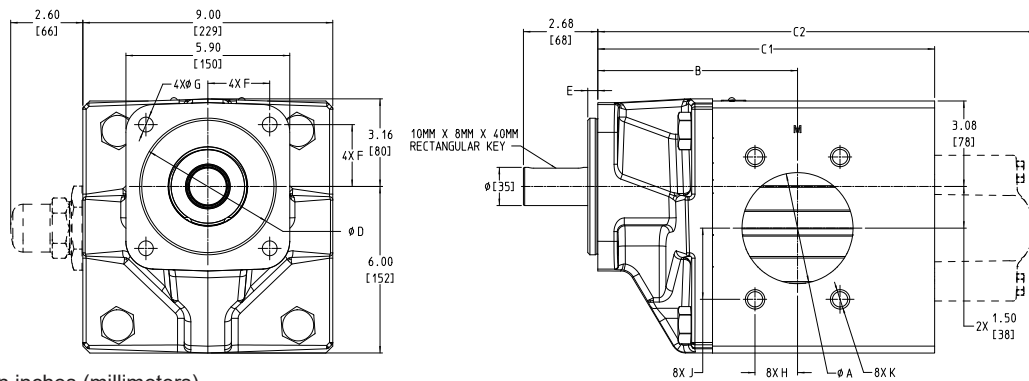

NOTE: Dimensions in inches (millimeters)

Model Number			A ③	B	C1	C2	D	E	F	G	H	J	K
SG-1420 ①	U	in	2.00	6.10	8.53	12.16	5.00	0.49	2.25	0.56	0.84	1.53	M12 X 1.75 X 19.5
SG-1420 ②	M	mm	51	155	217	309	125	9	57	14	21	39	M12 X 1.75 X 19.5
SG-1436 ①	U	in	3.00	6.80	10.13	13.76	5.00	0.49	2.25	0.56	1.22	2.09	M16 X 2.00 X 28.5
SG-1436 ②	M	mm	76	173	257	350	125	9	57	14	31	53	M16 X 2.00 X 28.5
SG-1456 ①	U	in	4.00	7.19	12.13	15.76	5.00	0.49	2.25	0.56	1.53	2.56	M16 X 2.00 X 28.5
SG-1456 ②	M	mm	102	183	308	400	125	9	57	14	39	65	M16 X 2.00 X 28.5

- ① Bracket pilot SAE-C 4-bolt standard for NEMA M-drive or foot bracket
- ② Bracket pilot 125 mm ISO 3019-2 DIN 4x standard for IEC M-drive or foot bracket
- ③ Standard ports SAE J518 code 61 flange. Optional tapped ports on same centerline include NPT or BSP (up to 4") or SAE O-Ring J1453 (up to 2")
- ④ Bracket pilot SAE C 4-Bolt or 125 mm ISO 3019-2

These dimensions are average and not for construction purposes. Certified prints on request.

**SPUR GEAR PRODUCT LINE:
CAST IRON PUMPS**

SERIES SG-04, SG-05, SG-07, SG-10, SG-14

Section	1451
Page	1451.11
Issue	B

DIMENSIONS – SG-04 & SG-05 SERIES NEMA C-FLANGE (M DRIVE)

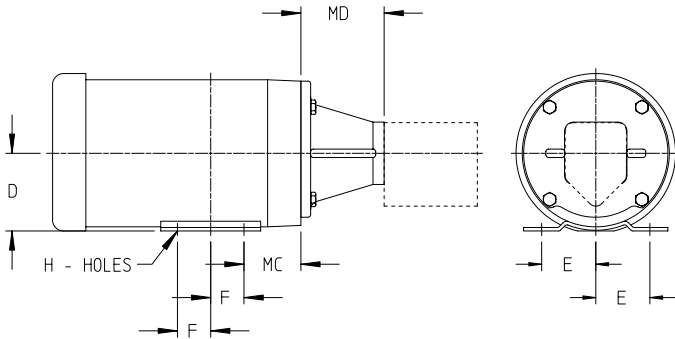

① Drive equipment weight listed is for a typical TEFC motor, mounting bracket and couplings. (If a more accurate motor shipping weight is required, consult factory with complete motor specifications.) For total unit shipping weight, add the drive equipment shipping weight to the pump shipping weight shown on the pump specification chart.

Motor Frame Size		D	E	F	H	MC	MD	Approximate Drive ① Equipment Shipping Weight In Pounds (KG)
56C	in (mm)	3.50 (88.9)	2.44 (62.0)	1.50 (38.1)	.34 (8.6) SLOT	2.56 (65.0)	3.75 (95.3)	34 (15)
143TC	in (mm)	3.50 (88.9)	2.75 (69.9)	2.00 (50.8)	.34 (8.6)	2.88 (73.2)	3.75 (95.3)	52 (24)
145TC	in (mm)	3.50 (88.9)	2.75 (69.9)	2.50 (63.5)	.34 (8.6)	2.88 (73.2)	3.75 (95.3)	57 (26)
182TC	in (mm)	4.50 (114.3)	3.75 (95.3)	2.25 (57.15)	.41 (10.4)	3.62 (92.0)	4.25 (108.0)	83 (38)
184TC	in (mm)	4.50 (114.3)	3.75 (95.3)	2.75 (69.9)	.41 (10.4)	3.62 (92.0)	4.25 (108.0)	88 (40)

DIMENSIONS – SG-07 SERIES NEMA C-FLANGE (M DRIVE)

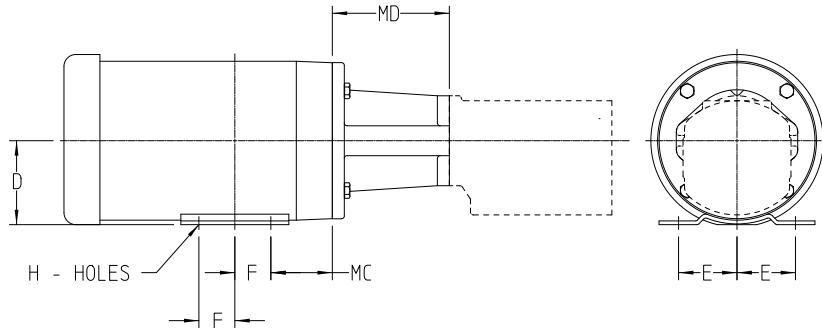

① Drive equipment weight listed is for a typical TEFC motor, mounting bracket and couplings. (If a more accurate motor shipping weight is required, consult factory with complete motor specifications.) For total unit shipping weight, add the drive equipment shipping weight to the pump shipping weight shown on the pump specification chart.

Motor Frame Size		D	E	F	H	MC	MD	Approximate Drive ① Equipment Shipping Weight In Pounds (KG)
56C	in (mm)	3.50 (88.9)	2.44 (62.0)	1.50 (38.1)	.34 (8.6) SLOT	2.56 (65.0)	4.88 (124.0)	41 (19)
143TC	in (mm)	3.50 (88.9)	2.75 (69.9)	2.00 (50.8)	.34 (8.6)	2.88 (73.2)	4.88 (124.0)	60 (27)
145TC	in (mm)	3.50 (88.9)	2.75 (69.9)	2.50 (63.5)	.34 (8.6)	2.88 (73.2)	4.88 (124.0)	70 (32)
182TC	in (mm)	4.50 (114.3)	3.75 (95.3)	2.25 (57.15)	.41 (10.4)	3.62 (92.0)	5.59 (142.0)	108 (49)
184TC	in (mm)	4.50 (114.3)	3.75 (95.3)	2.75 (69.9)	.41 (10.4)	3.62 (92.0)	5.59 (142.0)	123 (56)
213TC	in (mm)	5.25 (133.4)	4.25 (108.0)	2.75 (69.9)	.41 (10.4)	4.50 (114.3)	6.26 (159.0)	161 (73)
215TC	in (mm)	5.25 (133.4)	4.25 (108.0)	3.50 (88.9)	.41 (10.4)	4.50 (114.3)	6.26 (159.0)	195 (88)

These dimensions are average and not for construction purposes. Certified prints on request.

Section	1451
Page	1451.12
Issue	B

**SPUR GEAR PRODUCT LINE:
CAST IRON PUMPS**
SERIES SG-04, SG-05, SG-07, SG-10, SG-14

DIMENSIONS – SG-10 SERIES NEMA (M DRIVE)

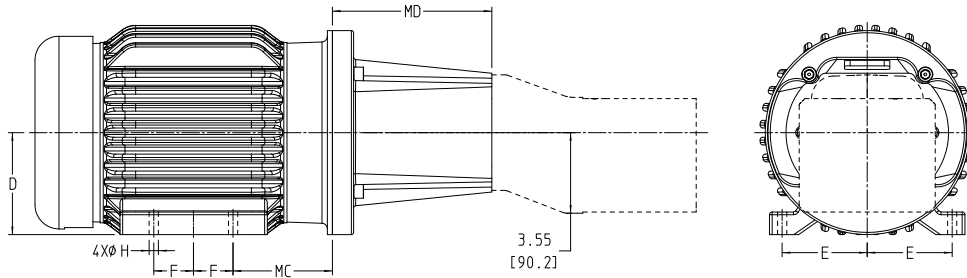

Motor Frame Size		D	E	F	H	MC	MD	Approximate Drive ① Equipment Shipping Weight In Pounds (KG)
56C	in (mm)	3.50 (88.9) ②	2.44 (62.0)	1.50 (38.1)	.34 (8.6)	2.56 (65.0)	5.06 (128.5)	49 (22.1)
143TC	in (mm)	3.50 (88.9) ②	2.75 (69.9)	2.00 (50.8)	.34 (8.6)	2.88 (73.2)	5.06 (128.5)	65 (29.7)
145TC	in (mm)	3.50 (88.9) ②	2.75 (69.9)	2.50 (63.5)	.34 (8.6)	2.88 (73.2)	5.06 (128.5)	74 (33.5)
182TC	in (mm)	4.50 (114.3)	3.75 (95.3)	2.25 (57.2)	.41 (10.4)	3.38 (85.9)	5.69 (144.5)	151 (68.6)
184TC	in (mm)	4.50 (114.3)	3.75 (95.3)	2.75 (69.9)	.41 (10.4)	3.38 (85.9)	5.69 (144.5)	159 (71.9)
213TC	in (mm)	5.25 (133.4)	4.25 (108.0)	2.75 (69.9)	.41 (10.4)	4.25 (108.0)	6.63 (168.4)	190 (86.1)
215TC	in (mm)	5.25 (133.4)	4.25 (108.0)	3.50 (88.9)	.41 (10.4)	4.25 (108.0)	6.63 (168.4)	257 (116.6)
254TC	in (mm)	6.25 (158.8)	5.00 (127.0)	4.13 (104.9)	.53 (13.5)	4.75 (120.7)	7.04 (178.8)	284 (128.9)
256TC	in (mm)	6.25 (158.8)	5.00 (127.0)	5.00 (127.0)	.53 (13.5)	4.75 (120.7)	7.04 (178.8)	328 (149.0)
284TC	in (mm)	7.00 (177.8)	5.50 (139.7)	4.75 (120.7)	.53 (13.5)	4.75 (120.7)	8.11 (206.0)	432 (195.8)
286TC	in (mm)	7.00 (177.8)	5.50 (139.7)	5.50 (139.7)	.53 (13.5)	4.75 (120.7)	8.11 (206.0)	485 (220.1)

① Drive equipment weight listed is for a typical TEFC motor, mounting bracket and couplings. (If a more accurate motor shipping weight is required, consult factory with complete motor specifications.) For total unit shipping weight, add the drive equipment shipping weight to the pump shipping weight shown on the pump specification chart.

② Pump extends below motor feet. Motor must be blocked up.

NOTE: Cartridge seals may not be used with M-Drives

DIMENSIONS – SG-14 SERIES NEMA (M DRIVE)

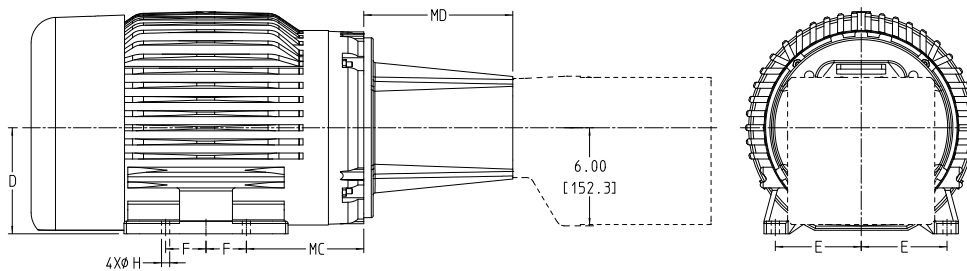

Motor Frame Size		D	E	F	H	MC	MD	Approximate Drive ① Equipment Shipping Weight In Pounds (KG)
213TC	in (mm)	5.25 (133.4) ②	4.25 (108.0)	2.75 (69.9)	.41 (10.4)	4.50 (114.3)	7.63 (193.8)	190 (86.1)
215TC	in (mm)	5.25 (133.4) ②	4.25 (108.0)	3.50 (88.9)	.41 (10.4)	4.50 (114.3)	7.63 (193.8)	257 (116.5)
254TC	in (mm)	6.25 (158.8)	5.00 (127.0)	4.13 (104.9)	.53 (13.5)	4.75 (120.7)	7.63 (193.8)	284 (128.9)
256TC	in (mm)	6.25 (158.8)	5.00 (127.0)	5.00 (127.0)	.53 (13.5)	4.75 (120.7)	7.63 (193.8)	328 (149.0)
284TC	in (mm)	7.00 (177.8)	5.50 (139.7)	4.75 (120.7)	.53 (13.5)	4.75 (120.7)	9.12 (231.6)	432 (195.8)
286TC	in (mm)	7.00 (177.8)	5.50 (139.7)	5.50 (139.7)	.53 (13.5)	4.75 (120.7)	9.12 (231.6)	485 (220.1)
324TC	in (mm)	8.00 (203.2)	6.25 (158.8)	5.25 (133.4)	.53 (13.5)	5.25 (133.4)	9.13 (231.6)	680 (308.5)

① Drive equipment weight listed is for a typical TEFC motor, mounting bracket and couplings. (If a more accurate motor shipping weight is required, consult factory with complete motor specifications.) For total unit shipping weight, add the drive equipment shipping weight to the pump shipping weight shown on the pump specification chart.

② Pump extends below motor feet. Motor must be blocked up.

These dimensions are average and not for construction purposes. Certified prints on request.

SPUR GEAR PRODUCT LINE: CAST IRON PUMPS

SERIES SG-04, SG-05, SG-07, SG-10, SG-14

Section	1451
Page	1451.13
Issue	B

DIMENSIONS – SG-04 & SG-05 SERIES IEC FRAME (M DRIVE)

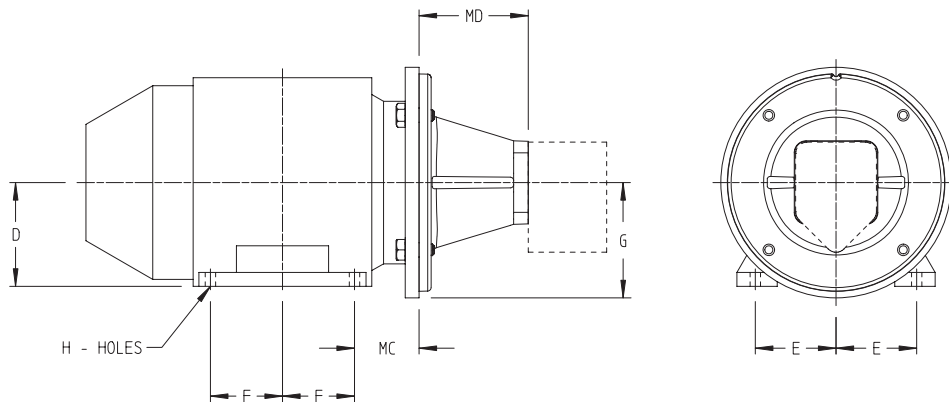

Motor Frame Size		D	E	F	G	H	MC	MD	Approximate Drive ① Equipment Shipping Weight In Pounds (KG)
IEC 80 B35 FLANGE	in (mm)	3.15 (80)	2.46 (62.5)	1.97 (50)	3.94 (100)	0.39 (10)	1.97 (50)	3.73 (94.7)	46 (21)
IEC 90 B35 FLANGE	in (mm)	3.54 (90)	2.76 (70)	S 1.97 (50) / L 2.46 (62.5)	3.94 (100)	0.39 (10)	2.20 (56)	3.73 (94.7)	64 (29)

- ① Motor shipping weight listed is for a typical IEC motor.
(If a more accurate motor shipping weight is required, consult factory with complete motor specifications.)
For total unit shipping weight, add the electric motor shipping weight to the pump shipping weight shown on the pump specification chart.

DIMENSIONS – SG-07 SERIES IEC FRAME (M DRIVE)

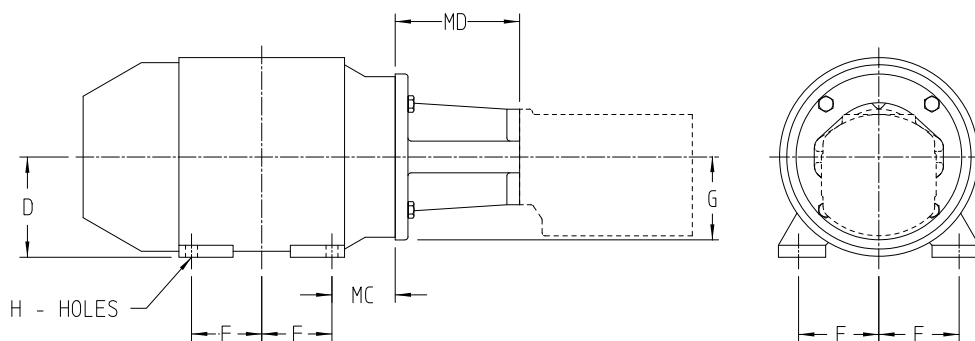

Motor Frame Size		D	E	F	G	H	MC	MD	Approximate Drive ① Equipment Shipping Weight In Pounds (KG)
IEC 90 B35 FLANGE	in (mm)	3.54 (90)	2.76 (70)	S 1.97 (50) / L 2.46 (62.5)	3.94 (100)	0.39 (10)	2.20 (56)	5.13 (130.3)	68 (31)
IEC 100 B14 FACE	in (mm)	3.94 (100)	3.15 (80)	S 2.20 (56) / L 2.76 (70)	—	0.47 (12)	2.48 (63)	5.26 (133.6)	114 (52)
IEC 112 B14 FACE	in (mm)	4.41 (112)	3.74 (95)	S 2.24 (57) / L 2.76 (70)	—	0.47 (12)	2.76 (70)	5.26 (133.6)	129 (59)

- ① Motor shipping weight listed is for a typical IEC motor.
(If a more accurate motor shipping weight is required, consult factory with complete motor specifications.)
For total unit shipping weight, add the electric motor shipping weight to the pump shipping weight shown on the pump specification chart.

These dimensions are average and not for construction purposes. Certified prints on request.

Section	1451
Page	1451.14
Issue	B

**SPUR GEAR PRODUCT LINE:
CAST IRON PUMPS**
SERIES SG-04, SG-05, SG-07, SG-10, SG-14

DIMENSIONS – SG-10 SERIES IEC B35 FRAME (M DRIVE)

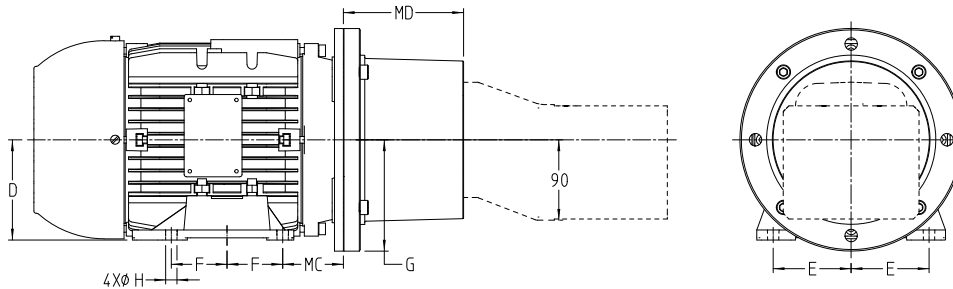

Motor Frame Size		D	E	F	G	H	MC	BELLHOUSING PN ②	MD	Approximate Drive ① Equipment Shipping Weight In Pounds (KG)
90	in (mm)	3.54 (90)	2.76 (70)	2.46 (62.5)	3.94 (100)	0.39 (10)	2.20 (56)	2-085-054-720-00	4.88 (124)	63 (28.8)
100L	in (mm)	3.94 (100)	3.15 (80)	2.76 (70)	3.94 (100)	0.47 (12)	2.48 (63)	2-085-050-720-00	5.31 (135)	89 (40.5)
112M	in (mm)	4.41 (112)	3.74 (95)	2.76 (70)	4.92 (125)	0.47 (12)	2.76 (70)	2-085-050-720-00	5.31 (135)	110 (49.9)
132S/M	in (mm)	5.20 (132)	4.25 (108)	2.76 (70)	5.91 (150)	0.47 (12)	3.50 (89)	2-085-051-720-00	5.31 (135)	179 (81.3)
160L	in (mm)	6.30 (160)	5.00 (127)	4.13 (105)	6.89 (175)	0.59 (15)	4.25 (108)	2-085-052-720-00	7.40 (188)	331 (150.3)
180L	in (mm)	7.09 (180)	5.49 (139.5)	4.74 (120.5)	6.89 (175)	0.59 (15)	4.76 (121)	2-085-052-720-00	7.40 (188)	496 (225.1)
200M	in (mm)	7.87 (200)	6.26 (159)	5.26 (133.5)	7.87 (200)	0.71 (18)	5.24 (133)	2-085-053-720-00	8.03 (204)	668 (303.3)

① Drive equipment weight listed is for a typical TEFC motor, mounting bracket and couplings. (If a more accurate motor shipping weight is required, consult factory with complete motor specifications.) For total unit shipping weight, add the drive equipment shipping weight to the pump shipping weight shown on the pump specification chart.

② Viking offers several bellhousing styles, and these dimensions only pertain to the bellhousing part numbers listed. If using a different part number, dimensions may vary.

NOTE: Cartridge seals may not be used with M-Drives

DIMENSIONS – SG-14 SERIES IEC B35 FRAME (M DRIVE)

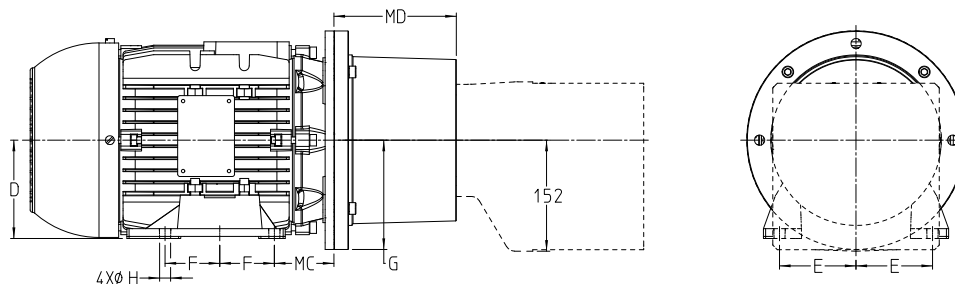

Motor Frame Size		D	E	F	G	H	MC	BELLHOUSING PN ②	MD	Approximate Drive ① Equipment Shipping Weight In Pounds (KG)
132	in (mm)	5.20 (132)	4.25 (108)	2.76 (70)	5.91 (150)	0.47 (12)	3.50 (89)	2-085-041-720-00	6.61 (168)	179 (81.3)
160	in (mm)	6.30 (160)	5.00 (127)	4.13 (105)	6.89 (175)	0.59 (15)	4.25 (108)	2-085-048-720-00	8.03 (204)	331 (150.3)
180	in (mm)	7.09 (180)	5.49 (139.5)	4.74 (120.5)	6.89 (175)	0.59 (15)	4.76 (121)	2-085-048-720-00	8.03 (204)	496 (225.1)
200	in (mm)	7.87 (200)	6.26 (159)	5.26 (133.5)	7.87 (200)	0.71 (18)	5.24 (133)	2-085-040-720-00	8.03 (204)	668 (303.3)
225	in (mm)	8.86 (225)	7.01 (178)	5.63 (143)	8.86 (225)	0.71 (18)	5.87 (149)	2-085-049-720-00	9.21 (234)	793 (359.9)

① Drive equipment weight listed is for a typical TEFC motor, mounting bracket and couplings. (If a more accurate motor shipping weight is required, consult factory with complete motor specifications.) For total unit shipping weight, add the drive equipment shipping weight to the pump shipping weight shown on the pump specification chart.

② Viking offers several bellhousing styles, and these dimensions only pertain to the bellhousing part numbers listed. If using a different part number, dimensions may vary.

NOTE: Cartridge seals may not be used with M-Drives

These dimensions are average and not for construction purposes. Certified prints on request.

**SPUR GEAR PRODUCT LINE:
CAST IRON PUMPS**

SERIES SG-04, SG-05, SG-07, SG-10, SG-14

Section	1451
Page	1451.15
Issue	B

DIMENSIONS – SG-04 & SG-05 SERIES 4-BOLT (M4 DRIVE)

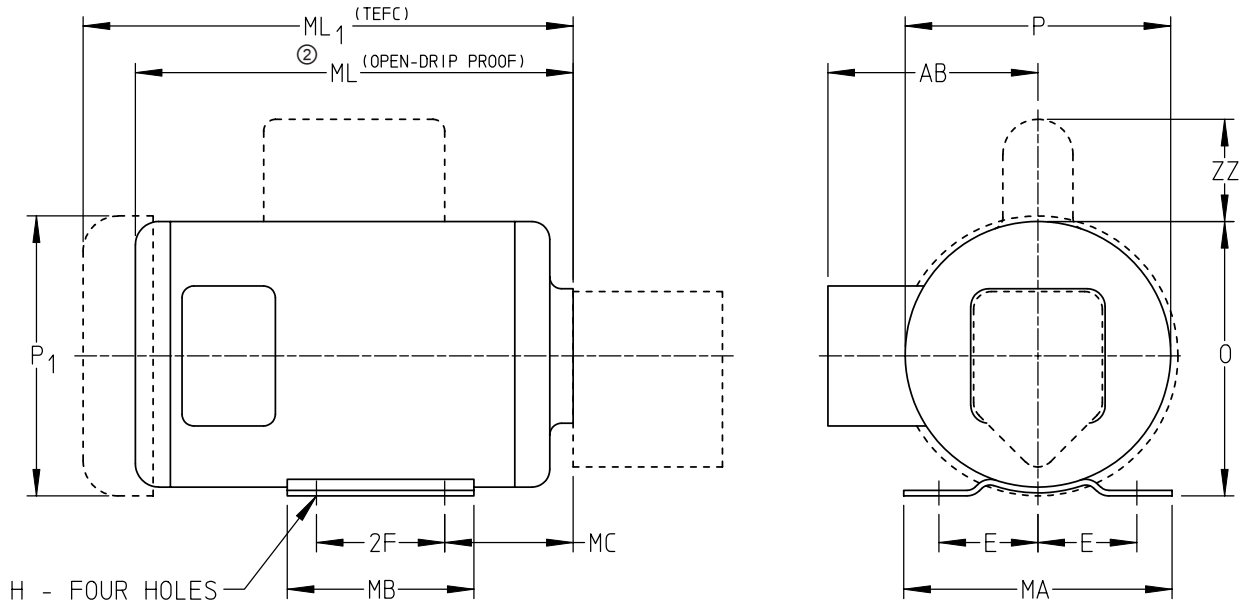

Close-Coupled Motor Frame Size		AB	D	E	2F	H	MA	MB	MC	ENCL.	O	P	P ₁	ZZ	Approximate Drive Equipment ^① Shipping Weight In Pounds (KG)
48 M4 Drive	in (mm)	4.50 (114)	3.00 (76)	2.12 (54)	2.75 (70)	.34 (9) SLOT	5.75 (146)	4.00 (102)	2.75 (70)	ODP	5.88 (149)	5.69 (145)	—	2.19 (56)	25 (11.1)
										TEFC	5.88 (149)	—	6.12 (155)	2.25 (57)	
56 M4 Drive	in (mm)	5.25 (113)	3.50 (89)	2.44 (62)	3.00 (76)	.34 (9) SLOT	6.50 (165)	4.50 (114)	2.62 (66)	ODP	6.88 (175)	6.62 (168)	—	2.25 (57)	29 (12.9)
										TEFC	6.88 (175)	—	7.19 (183)	2.25 (57)	

① Drive equipment weight listed is for a typical TEFC motor, mounting bracket and couplings. (If a more accurate motor shipping weight is required, consult factory with complete motor specifications.) For total unit shipping weight, add the drive equipment shipping weight to the pump shipping weight shown on the pump specification chart.

② ML and ML₁ length dependent on motor horsepower.

NOTE: Dimensions in inches (mm).

Section	1451
Page	1451.16
Issue	B

**SPUR GEAR PRODUCT LINE:
CAST IRON PUMPS**
SERIES SG-04, SG-05, SG-07, SG-10, SG-14

DIMENSIONS – SG-04 & SG-05 SERIES (B DRIVE)

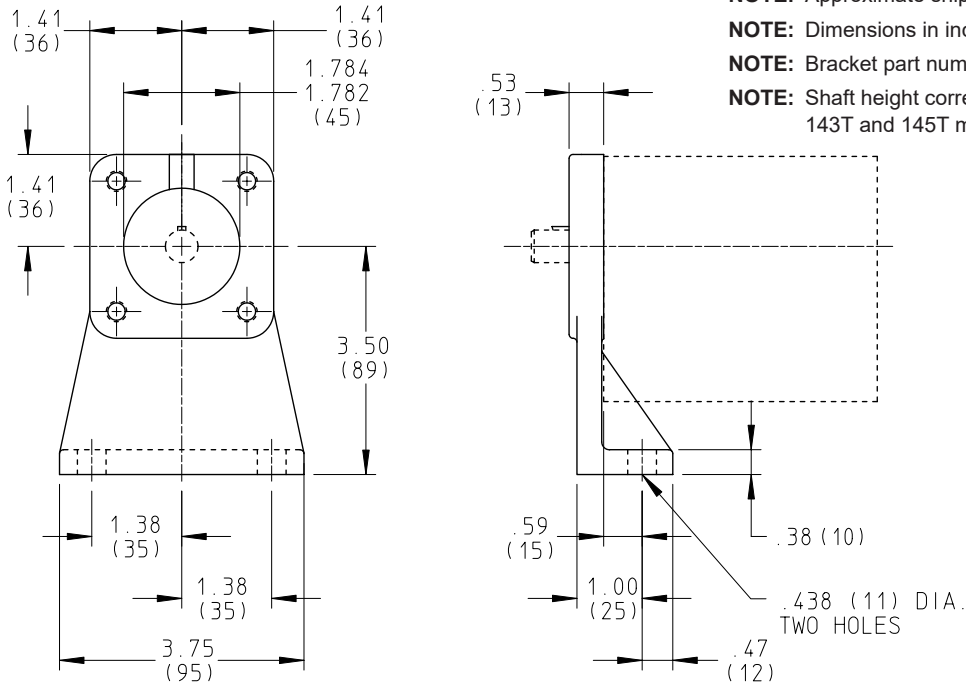

- NOTE: Approximate shipping weight of foot bracket is 2¼ lbs. (0.9 kg)
- NOTE: Dimensions in inches (millimeters).
- NOTE: Bracket part number is 2-070-012-100-00
- NOTE: Shaft height corresponds to Viking's "A" reducer or NEMA 56, 143T and 145T motors.

DIMENSIONS – SG-07 SERIES (B DRIVE)

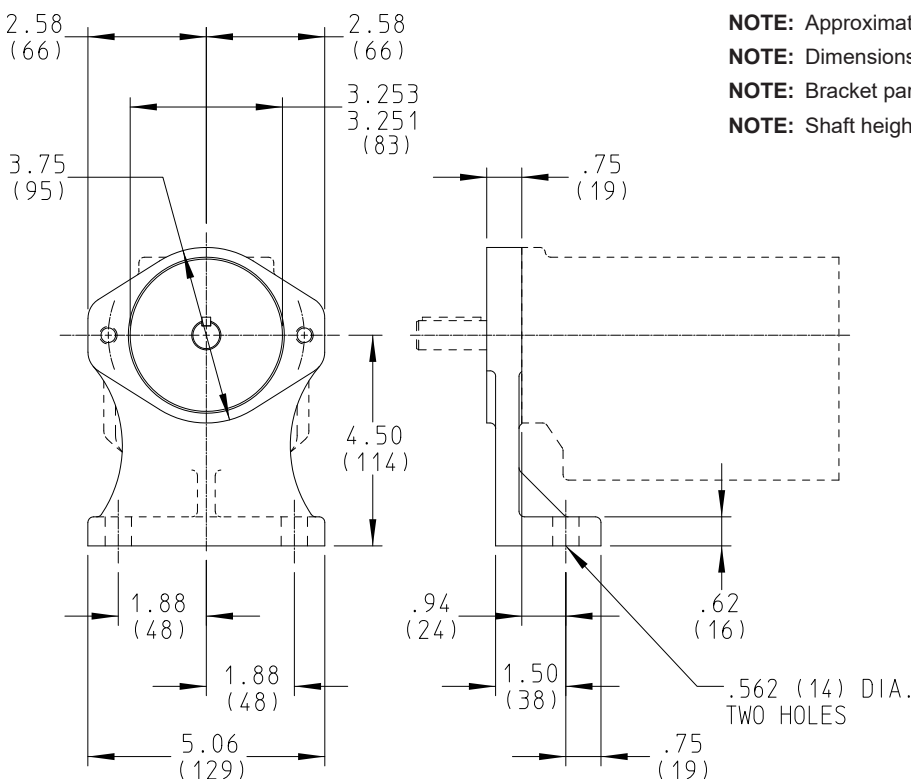

- NOTE: Approximate shipping weight of foot bracket is 5 lbs. (1.9 kg)
- NOTE: Dimensions in inches (millimeters).
- NOTE: Bracket part number is 2-070-200-100-00
- NOTE: Shaft height corresponds to NEMA 182T and 184T motors.

These dimensions are average and not for construction purposes. Certified prints on request.

SPUR GEAR PRODUCT LINE: CAST IRON PUMPS

SERIES SG-04, SG-05, SG-07, SG-10, SG-14

Section	1451
Page	1451.17
Issue	B

DIMENSIONS – SG-10 SERIES (B DRIVE)

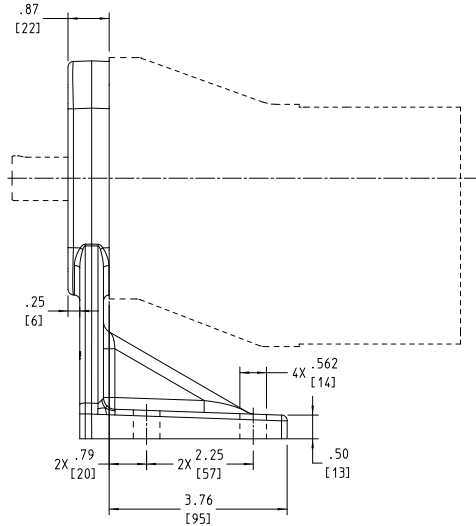
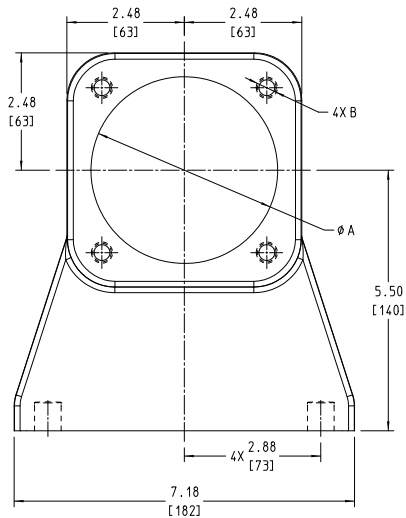

For Use With		A	B
PILOT: SAE B 4 BOLT ("U" BRACKET) P/N 2-070-301-100-00	in	4.00	½ - 13
PILOT: ISO 100MM 4 BOLT ("M" BRACKET) P/N 2-070-300-100-00	mm	100	M10 X 1.5

NOTE: Approximate shipping weight is 11 lbs. (4.8 kg)

NOTE: Dimensions in inches (millimeters).

NOTE: Shaft height corresponds to Viking's "B" reducer.

DIMENSIONS – SG-14 SERIES (B DRIVE)

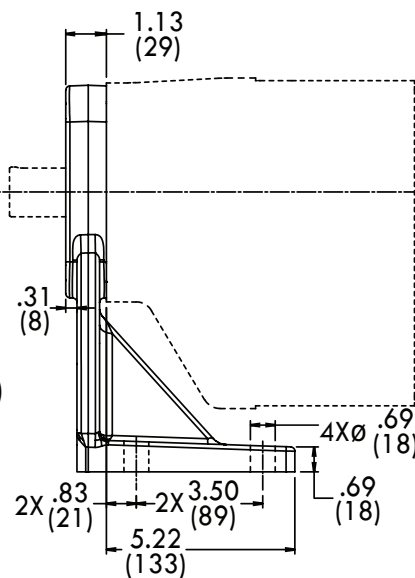
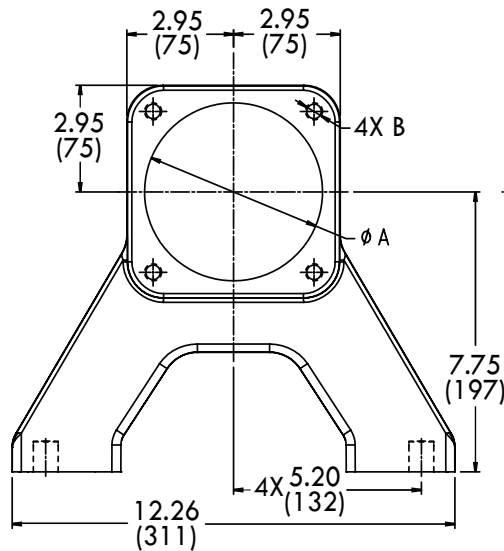

For Use With		A	B
PILOT: SAE C 4 BOLT ("U" BRACKET) P/N 2-070-400-100-00	in	5.00	½ - 13
PILOT: ISO 125MM 4 BOLT ("M" BRACKET) P/N 2-070-401-100-00	mm	125	M12 X 1.75

NOTE: Approximate shipping weight is 19 lbs. (8.6 kg)

NOTE: Dimensions in inches (millimeters).

NOTE: Shaft height corresponds to Viking's "C" reducer.

Section	1451
Page	1451.18
Issue	B

**SPUR GEAR PRODUCT LINE:
CAST IRON PUMPS**
SERIES SG-04, SG-05, SG-07, SG-10, SG-14

DIMENSIONS – SG-04 & SG-05 SERIES (D DRIVE)

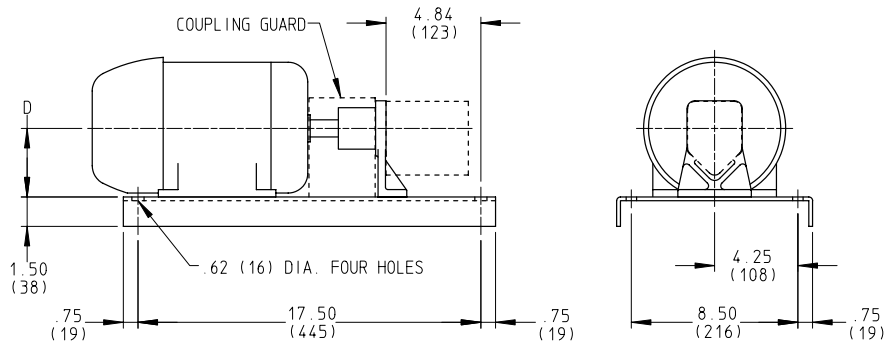

Motor Frame Size		D	Approximate Motor ① Shipping Weight In Pounds (KG)	Approximate Drive ① Equipment Shipping Weight In Pounds (KG)
56	in (mm)	3.50 (89)	31 (14)	17 (8)
143T	in (mm)	3.50 (89)	50 (23)	17 (8)
145T	in (mm)	3.50 (89)	60 (27)	17 (8)
182T	in (mm)	4.50 (114)	95 (43)	20 (9)
184T	in (mm)	4.50 (114)	110 (50)	20 (9)

- ① Motor shipping weight listed is for a typical TEFC motor. (If a more accurate motor shipping weight is required, consult factory with complete motor specifications.)
- ② Drive equipment shipping weight includes base, foot-bracket, coupling and coupling guard. For total unit shipping weight, add electric motor shipping weight, drive equipment shipping weight and the pump shipping weight shown on the pump specification chart.

DIMENSIONS – SG-07 SERIES (D DRIVE)

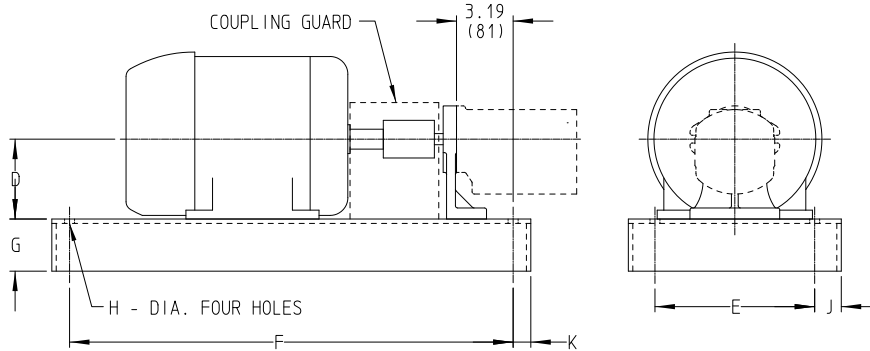

Motor Frame Size		D	E	F	G	H	J	K	Approximate Motor ① Shipping Weight In Pounds (KG)	Approximate Drive ① Equipment Shipping Weight In Pounds (KG)
56	in (mm)	4.50 (114)	8.50 (216)	20.50 (520)	1.50 (190)	0.50 (13)	0.75 (19)	0.75 (19)	31 (14)	38 (17)
143T		50 (23)								
145T		60 (27)								
182T	in (mm)	4.50 (114)	9.00 (229)	25.00 (635)	2.94 (75)	0.56 (14)	1.50 (38)	1.00 (25)	95 (43)	49 (22)
184T		110 (50)								
213T	in (mm)	5.25 (133)	9.00 (229)	25.00 (635)	2.94 (75)	0.56 (14)	1.50 (38)	1.00 (25)	145 (66)	56 (25)
215T		179 (81)								

- ① Motor shipping weight listed is for a typical TEFC motor. (If a more accurate motor shipping weight is required, consult factory with complete motor specifications.)
- ② Drive equipment shipping weight includes base, foot-bracket, coupling and coupling guard. For total unit shipping weight, add electric motor shipping weight, drive equipment shipping weight and the pump shipping weight shown on the pump specification chart.

These dimensions are average and not for construction purposes. Certified prints on request.

SPUR GEAR PRODUCT LINE: CAST IRON PUMPS

SERIES SG-04, SG-05, SG-07, SG-10, SG-14

Section	1451
Page	1451.19
Issue	B

NPSH REQUIRED

Printed performance curves are not available.

Performance curves can be electronically generated with the Viking Pump Curve Generator on vikingpump.com.

NPSHR data is not available on the pump selector.

NPSH (Net Positive Suction Head): The $NPSH_R$ (Net Positive Suction Head Required by the pump) is given in the table below and applies for viscosities through 750 SSU. $NPSH_A$ (Net Positive Suction Head – Available in the system) must be greater than the $NPSH_R$. For a complete explanation of NPSH, see Application Data Sheet AD-19.

FOR VISCOSITIES UP TO 750 SSU – See $NPSH_R$ table below.

$NPSH_R$ for high viscosities can be estimated using the following method:

1. Calculate line loss for a 1 foot long pipe of a diameter matching the pump inlet port size. Use your flow rate and max viscosity.
2. Convert this value into Feet of Liquid (S.G. 1.0)
3. Add this value to the $NPSH_R$ value in the chart below.

$NPSH_R$ (At Pump Suction Port) – FEET OF LIQUID (Specific Gravity 1.0), Viscosities up to 750 SSU

PUMP SIZE	PUMPS SPEED, RPM							
	640	780	950	1150	1450	1750	2900	3450
SG-04 (all sizes)	—	—	—	—	—	9.5	11.5	13
SG-0518	3.2	3.2	3.2	3.2	3.2	3.2	5	6.2
SG-0525	3.2	3.2	3.2	3.3	3.4	3.4	5.4	6.6
SG-0535	3.3	3.4	3.4	3.5	3.6	3.7	5.8	7.1
SG-0550	3.4	3.5	3.6	3.8	4	4.3	6.6	8
SG-0570	3.6	3.9	4.1	4.4	4.9	5.5	8.2	9.8
SG-0510 ①	2.5	2.6	2.7	2.8	3.7	4.3	8.2	9.8
SG-0514 ①	2.5	2.6	2.7	2.8	3.7	4.3	9	11.5
SG-0519 ①	2.6	2.7	2.8	3.2	4	5	10.8	13.5
SG-0528 ①	3	3.2	3.4	3.9	4.9	6.2	14	17.5
SG-0729	3	3.1	3.1	3.2	3.8	4.8	11.1	15.6
SG-0741	3	3.1	3.1	3.2	3.8	4.8	11.3	16
SG-0758	3	3.1	3.1	3.2	3.8	4.8	11.8	16.6
SG-0782	3	3.1	3.1	3.2	3.8	4.8	12.8	17.6
SG-0711	3	3.1	3.1	3.2	3.8	5	15.2	20.6
SG-0716	3	3.1	3.1	3.2	4.5	6.5	21	27.6
SG-0722 ②	3	3.1	3.1	3.2	3.8	5	—	—
SG-0732 ②	3	3.1	3.1	3.2	4.5	6.5	—	—
SG-1013	5.6	6	6.6	7.5	9.2	11.5	—	—
SG-1026	5.8	6.2	6.9	8	10.1	12.8	—	—
SG-1420	6.9	7.4	8.2	9.4	11.8	15	—	—
SG-1436	7	7.7	8.7	10.2	13.3	17.5	—	—
SG-1456	7.2	8	9.3	11.2	15.3	20.9	—	—

① - Standard ports are in casing

② - 1½" tapped suction port standard