

Operating manual for micro annular gear pump
mzr-2509 Ex/ mzr-2909 Ex / mzr-4609 Ex / mzr-7209 Ex



HNP Mikrosysteme GmbH
Bleicherufer 25
D-19053 Schwerin (Germany)
Telephone: +49 385/52190-301
Telefax: +49 385/52190-333
E-mail: info@hnp-mikrosysteme.de
<http://www.hnp-mikrosysteme.de>

Last update: October 2016

Impressum

Original instructions

Copyright

HNP Mikrosysteme GmbH
Bleicherufer 25
D-19053 Schwerin

All rights, including translation, reserved.

Without prior explicit written permission of HNP Mikrosysteme GmbH no part of this manual may be, copied, reproduced or processed.

This manual has been prepared with care. HNP Mikrosysteme does assume no liability for any errors in this manual and resulting consequences. Likewise, no liability is assumed direct or subsequent damages arising from an incorrect use of the devices.

While using micro annular gear pumps, the relevant standards regarding the specifications of this manual have to be followed.

Subject to change without notice.

Contents

1	General Information	1
1.1	Use	1
1.2	Pump model designation	2
1.3	Technical data of the micro annular gear pumps	3
1.4	Measurements and flow charts of the m zr-2509 Ex pump	5
1.5	Measurements and flow charts of the m zr-2909 Ex pump	6
1.6	Measurements and flow charts of the m zr-4609 Ex pump	7
1.7	Measurements and flow charts of the m zr-7209 Ex pump	8
1.8	Technical data of the Ex-motor	9
1.9	Technical data of the alternativ brushless DC Ex-motor (X2 version)	12
2	Safety instructions	16
2.1	Labeling of instructions in the operation manual	16
2.2	Staff qualification and training	16
2.3	Safety conscious work	17
2.4	Safety instructions for the operator	17
2.5	Safety instructions for maintenance, inspection and assembly	18
2.6	Unauthorized modification and original spare parts	18
2.7	Improper mode of operation	18
2.8	General safety instructions	19
3	Transport and storage	20
3.1	Shipping pumps and protection measures	20
3.2	Transport damage	20
3.3	Interim storage	20
3.4	Conservation for storage after operation	20
4	Description of the pump	21
4.1	Principle of the micro annular gear pumps	21
4.2	Construction	23
4.3	Materials and liquids	23
4.4	Fluidic connectors	24
5	Modular system	25
5.1	Fluidic seal module	25
5.2	Heat insulation modul	28
5.3	Fluidic heating- and cooling module	29
5.3.1	Construction materials of heating- and cooling module	31
5.4	Gas-tight seal module	31

6	Mounting / Installation	32
6.1	Check before installation	32
6.2	Details place of operation	32
6.3	Mounting of the micro annular gear pump	32
6.4	Electrical Connections	33
6.5	Assembly instruction for tubing and accessories	33
6.6	Filter selection and use	35
6.7	Requirements for motor controller	36
6.8	Operation with motion controller S-HD-KL	37
6.9	Connection of the micro annular gear pump with S-G05	40
6.9.1	Startup with potentiometer	42
6.9.2	Startup with external 0-10 V signal	43
6.9.3	Startup with an external 0(4)-20 mA current signal	44
6.9.4	Startup with external potentiometer	46
6.9.5	Startup with the RS-232 interface	47
6.10	Installation of the software »Motion Manager«	48
7	Start up / Shut down	49
7.1	Prepare for start up	49
7.2	First start of a mzr-pump	49
7.3	Re-start after dry run	49
7.4	Operation of the micro annular gear pumps in different temperature ranges	50
7.5	Monitoring of operation in the temperature range T5, T6	51
7.6	Flushing procedure after use	51
7.7	Shutdown of the micro annular gear pump	54
7.7.1	Conservation	56
7.7.2	Dismantling of the system	57
7.8	Trouble shooting	58
7.9	Return of the micro annular gear pump to the manufacturer	58
8	Maintenance and service	59
8.1	Micro annular gear pumps	59
8.2	Metal bellow-type coupling	59
8.3	Ex-Motor	59
9	Problems and their removal	60
10	Software »Motion Manager«	63
10.1	Command mode	63
10.2	Programming of motion controller	65
10.3	Transfer of mcl-files to motor controller	65
11	Accessories	83
12	Non-warranty	83

13	EC Directive	84
13.1	Electromagnetic Compatibility (EMC)	85
1.1.1	EMC Directive and Standards	85
1.1.2	Information on use as intended	86
14	Declarations of conformity	88
15	Contact persons	104
16	Legal information	105
17	Safety information for the return of already employed micro annular gear pumps and components	106
17.1	General information	106
17.2	Declaration of liquids in contact with the micro annular gear pump	106
17.3	Shipment	106
18	Declaration of media in contact with the micro annular gear pump and its components	107
19	Appendix	108

1 General Information

Please read the »manual for micro annular gear pump« carefully before initial operation of the pump. The manuals for motor and control have to be seen as part of the pump manual. For missing manuals please call your distributor or HNP Mikrosysteme directly. Manuals are also available to download at www.hnp-mikrosysteme.de.

In case assistance is needed, please indicate the pump type visible on the housing.

1.1 Use

The micro annular gear pumps described in this manual are suitable for continuous delivery and discrete dosage of water, watery solutions, solvents, methanol, oils, lubricating liquids, paints and varnishes as well as many other liquids.



If you intend to treat any aggressive, poisonous, or radioactive liquids, you must conform to safety measures as according to the regulations in force. Any project concerning handling of corrosive liquids should be previously discussed with the pump manufacturer.



The micro annular gear pumps *must not* be used for invasive medical applications, in which the liquid having had contact with the pump is re-introduced to the body.



Micro annular gear pumps exclusively are provided for use in the industrial area. A private use is excluded.



The micro annular gear pumps *must not* be used in aircrafts and spacecrafts or other vehicles without prior consent of the manufacturer.



Data concerning resistance of the pumps to the manipulated liquids have been elaborated according to the best of HNPM's knowledge. However, operating parameters varying from one application case to another, no warranty for this information can be given.



Information given in this manual does not release the customer from the personal obligation to check the integrity, correct choice and suitability of the pump for the intended use. The use of the micro annular gear pumps should be conform with technical norms and regulations in force.

If you wish to receive more information than comprised in this manual please contact directly HNP Mikrosysteme.





1.2 Pump model designation

This manual is valid for the micro annular gear pump m zr-2509 Ex, m zr-2909 Ex, m zr-4609 Ex and m zr-7209 Ex manufactured by HNP Mikrosysteme GmbH, Bleicherufer 25, D-19053 Schwerin, Germany.

The bottom line of this manual shows issue and date of issue of the manual.

The micro annular gear pumps described in the operation manual are conform to the applicable EC standards and are permitted to bear the CE mark.

1.3 Technical data of the micro annular gear pumps

	mzr-2509 Ex, mzr-2509X2 Ex	mzr-2909 Ex, mzr-2909X2 Ex	mzr-4609 Ex, mzr-4609X2 Ex	mzr-7209 Ex, mzr-7209X2 Ex	Unit [UOM]
Explosion-protection					
Ex-certification	CE  II 2G c IIC T5 X	CE  II 2G c IIC T5 X	CE  II 2G c IIC T5 X	CE  II 2G c IIC T4 X	
Temperature class	T5	T5	T5	T4	
Ambient temperature	0 ... +40	0 ... +40	0 ... +40	0 ... +40	°C
Installation place	Ex-area zone 1, 2	Ex-area zone 1, 2	Ex-area zone 1, 2	Ex-area zone 1, 2	
Protection categories	c, d (Ex-motor)	c, d (Ex-motor)	c, d (Ex-motor)	c, d (Ex-motor)	
Measurements and weight					
Pump head diameter	23	23	23	35	mm
Length (without fluid connector)	approx. 278	approx. 278	approx. 281	approx. 294	mm
Width	75	75	75	75	mm
Height	85	85	85	85	mm
Weight	approx. 2500	approx. 2500	approx. 2500	approx. 2700	g
Weight (X2 version)	approx. 2700	approx. 2700	approx. 2700	approx. 2900	g
Specification					
Flow rate (by 0 bar)	0,0015 – 7	0,003 – 14	0,012 - 56	0,048 – 225	ml/min
Flow rate (by 0 bar) X2 Version	0,0015 – 6	0,003 – 12	0,012 - 48	0,048 – 192	ml/min
Smallest dosage volume	0,25	0,5	2	5	µl
Displacement volume	1,5	3	12	48	µl
Internal volume	84	85	109	525	µl
Operating pressure range by Viskosity 1 mPas	2	4	8	30	bar
Operating pressure range by Viskosity 16mPas	5	5	10	30	bar
Max. inlet pressure	5	5	5	5	bar
Speed range	1 – 4.700	1 – 4.700	1 – 4.700	1 – 4.700 *	U/min
Speed range X2 version	1 – 4.000	1 – 4.000	1 – 4.000	1 – 4.000 *	U/min
viscosity range of pumpable liquids	0,3 – 5 000 (10 000 mPas **)	0,3 – 5 000 (10 000 mPas **)	0,3 – 5 000 (10 000 mPas **)	0,3 – 5 000 (10 000 mPas **)	mPas
Pulsation	< 6	< 6	< 6	< 6	%
Liquid temperature	-5 ... +40 (-20 ... +130 **)	-5 ... +40 (-20 ... +130 **)	-5 ... +40 (-20 ... +130 **)	-5 ... +40 (-20 ... +130 **)	°C
Ambient temperature	0 ... +40	0 ... +40	0 ... +40	0 ... +40	°C
Storage temperature	0 ... +40	0 ... +40	0 ... +40	0 ... +40	°C

*) Values are specified for water with viscosity 1 mPas. Differing specifications on request

**) Differing specifications on request

Table 1 Technical data micro annular gear pumps mzr-2509 Ex / mzr-2909 Ex / mzr-4609 Ex / mzr-7209 Ex

Warning

The material properties of a liquid (e.g. viscosity, lubricating property, particle content, corrosiveness) impacts the technical data and the lifetime of pumps. Under appropriate conditions the characteristic values may be increased or decreased.

Warning

If you intend to operate the pump out of the range of the above given specification, please consult the manufacturer. Modifications may be necessary to ensure successful operation. Otherwise the pump or the system may be damaged seriously.

1.4 Measurements and flow charts of the m zr-2509 Ex pump

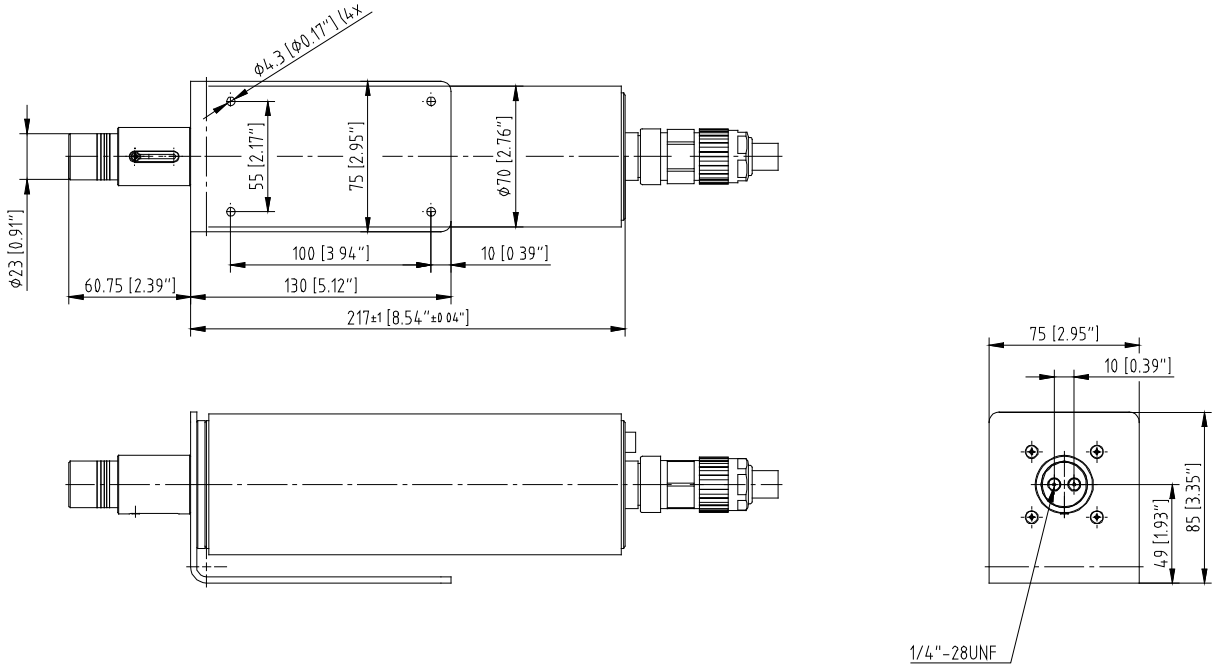

Figure 1 Measures of the micro annular gear pump m zr-2509 Ex

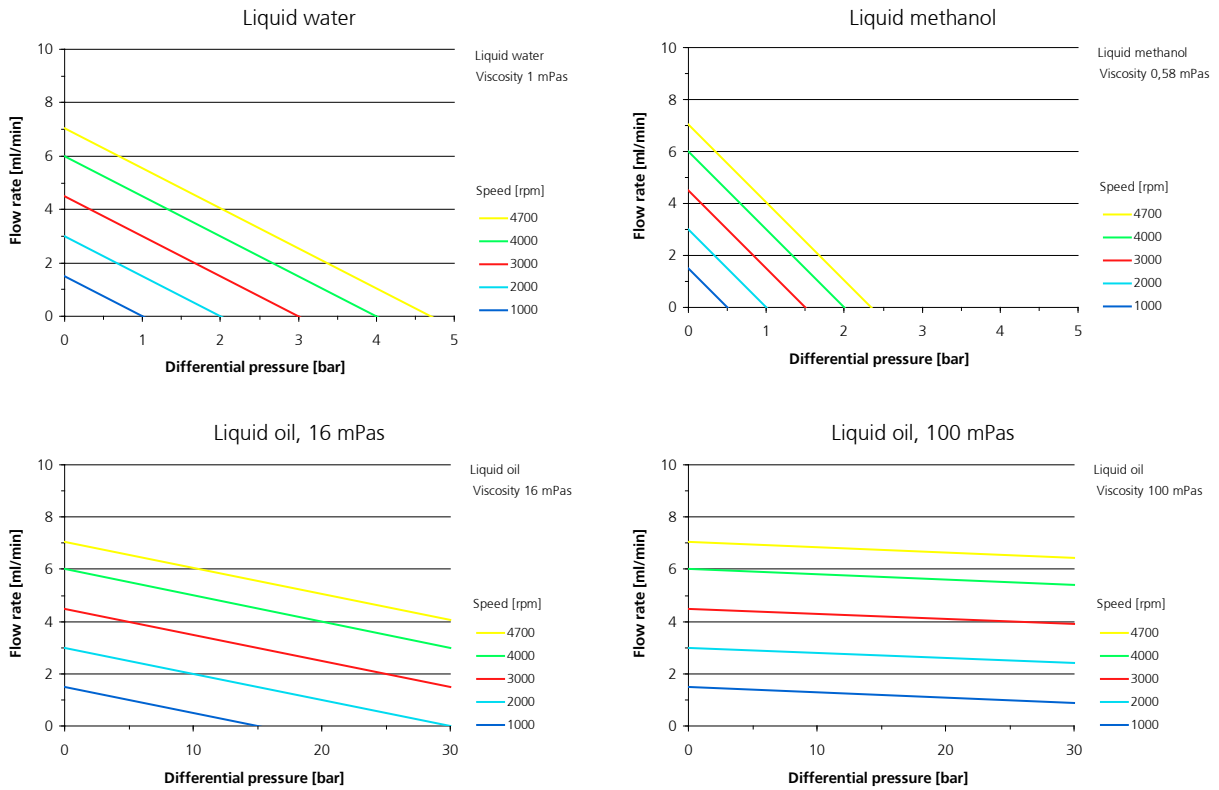

figure 2 Flow charts of the micro annular gear pump m zr-2909 Ex

1.5 Measurements and flow charts of the mzr-2909 Ex pump

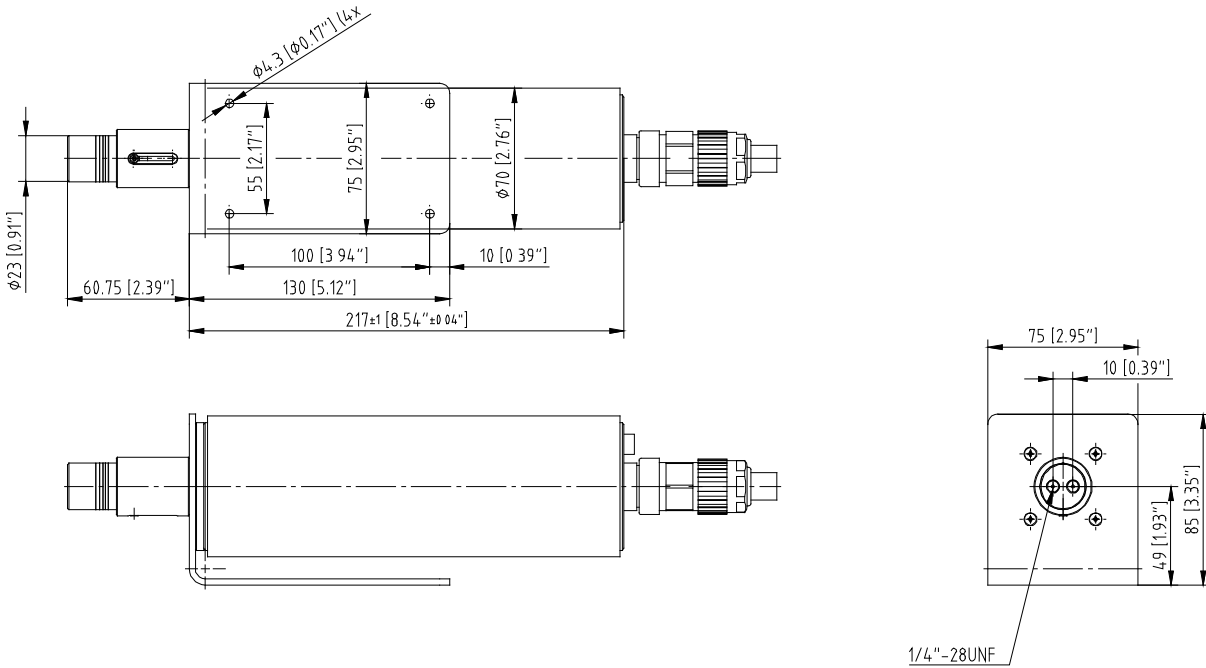

Figure 3 Measures of the micro annular gear pump mzr-2909 Ex

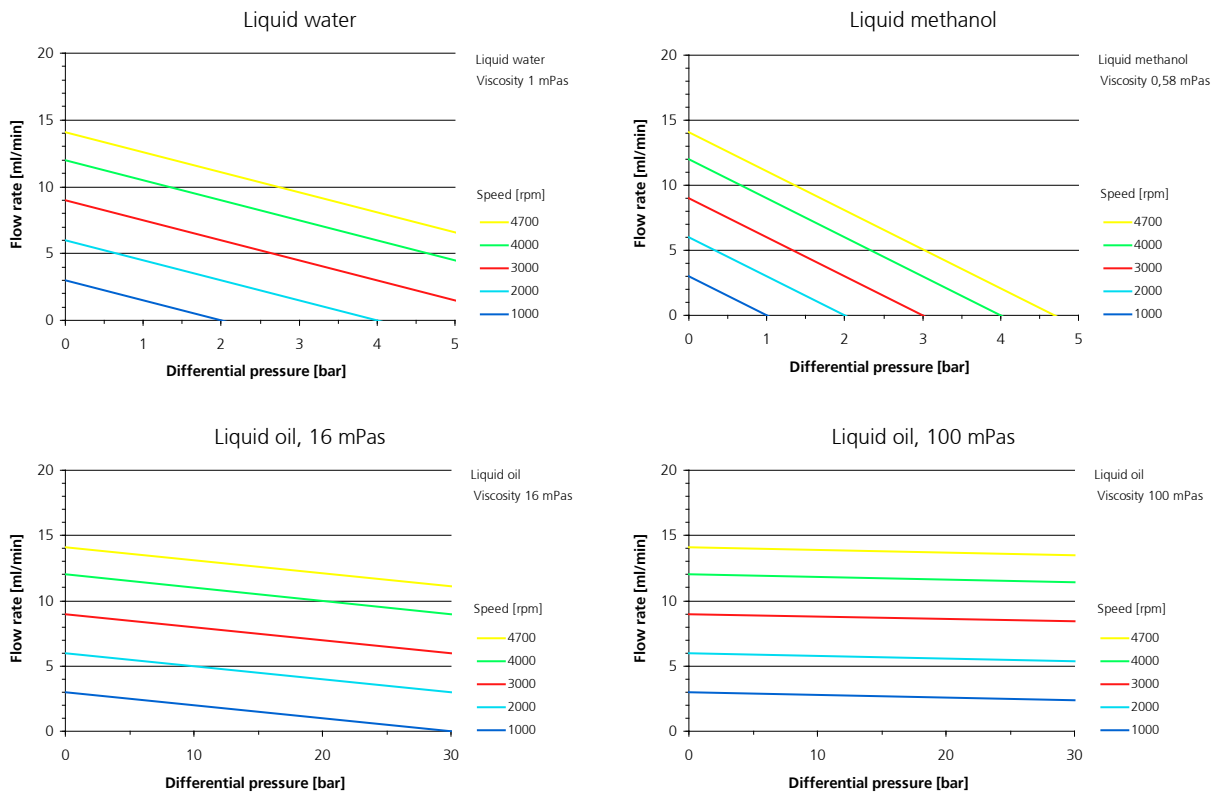

figure 4 Flow charts of the micro annular gear pump mzr-2909 Ex

1.6 Measurements and flow charts of the m zr-4609 Ex pump

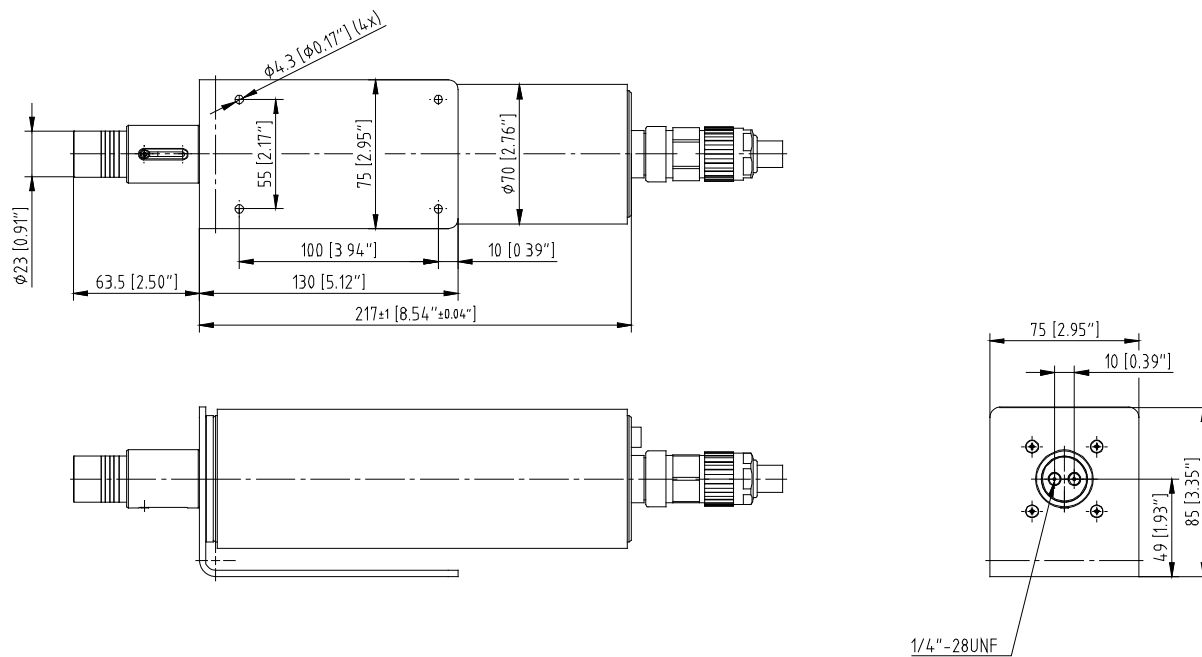

Figure 5 Measures of the micro annular gear pump m zr-4609 Ex (UOM: mm)

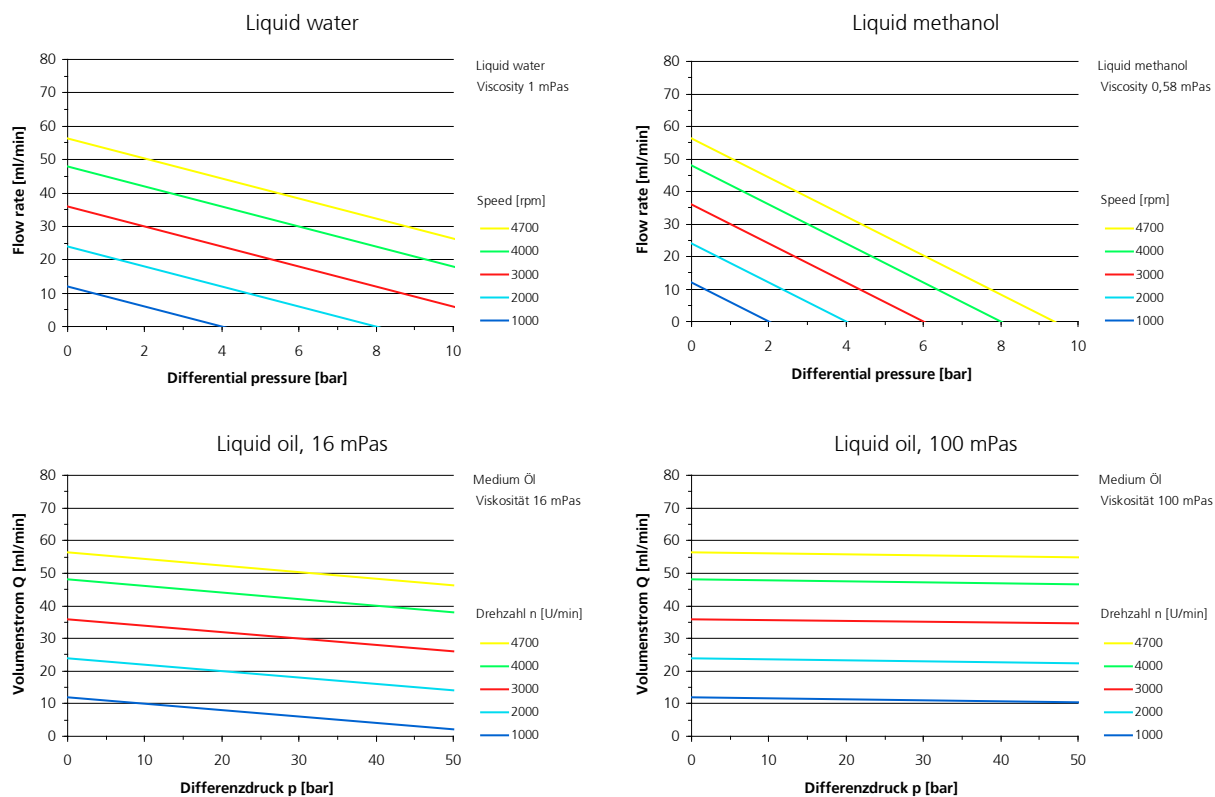

figure 6 Flow charts of the micro annular gear pump m zr-4609 Ex

1.7 Measurements and flow charts of the mzr-7209 Ex pump

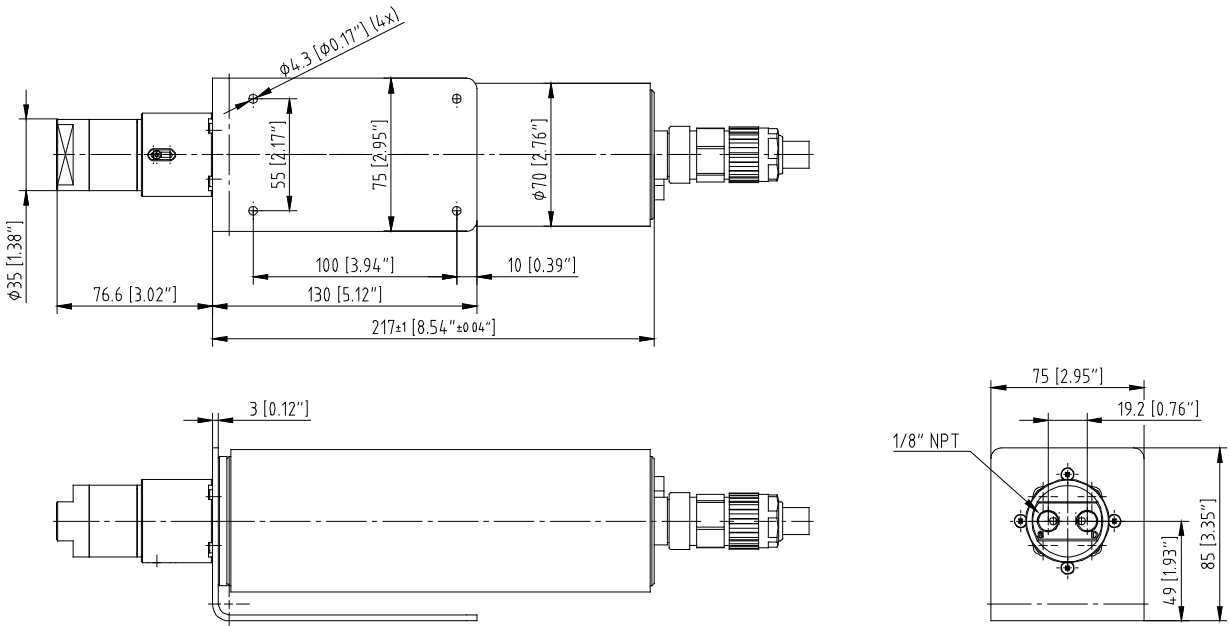

Figure 7 Measures of the micro annular gear pump mzr-7209 Ex

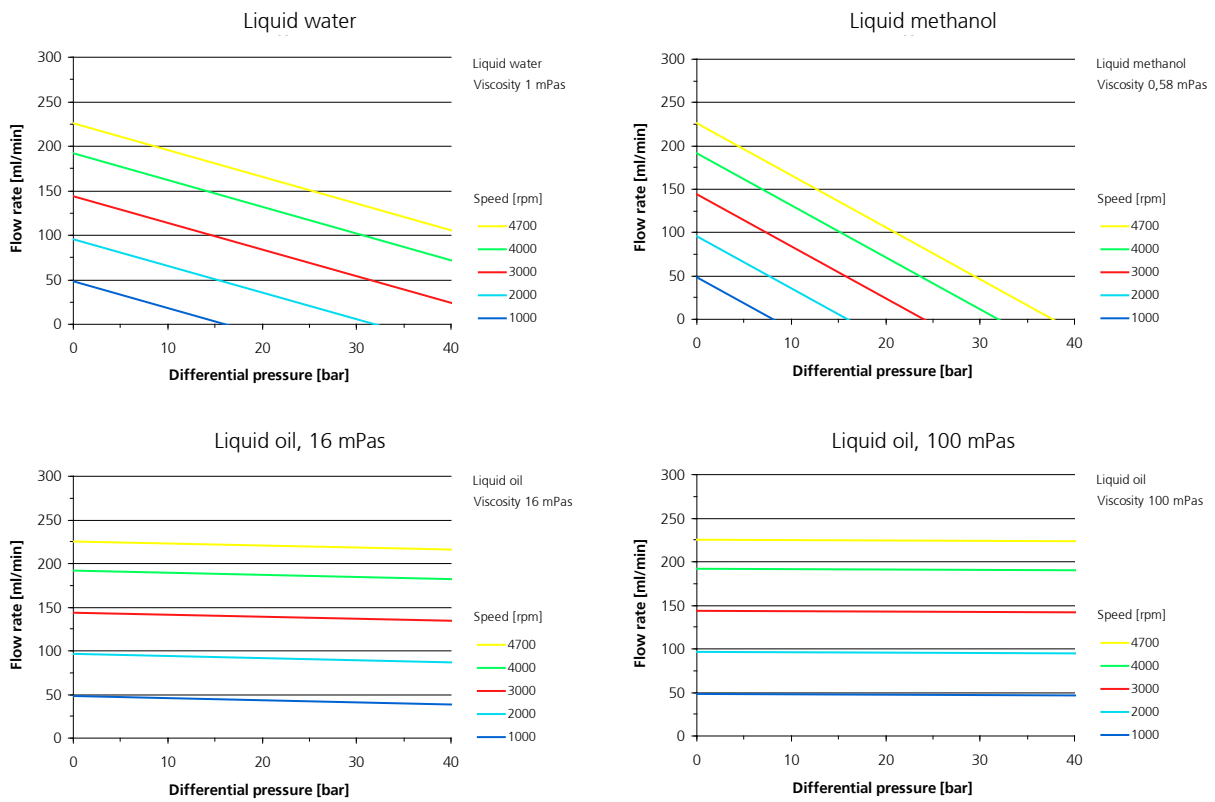

figure 8 Flow charts of the micro annular gear pump mzr-7209 Ex

1.8 Technical data of the Ex-motor

The micro annular gear pumps m zr-2509 Ex, m zr-2909 Ex, m zr-4609 Ex, m zr-7209 Ex are equipped with an explosion-proof DC-motor. The parameters of the motor are described in Table 2. The speed of the motor can be controlled with the optional motion controller S-HD-KL. One of the motor's features is a highly dynamic behavior. For operation it is recommended to use a power source of 24 V (with a power rating of 5 A).

The motor of the pumps is corresponding to the applicable EC standards. The confirmations according to EC 94/9/EG as well as of EC conformity are given.

Measurements	
Diameter of motor casing	70 mm
Length of motor casing	210 mm
Weight	approx. 1,8 kg
General data	
Type	EXR-1.24HEDL-L10
Manufacturer	Edelweiss Actuators Srl, Via Padergnone 21 I-24050 Zanika BG Italy
Distribution / Service	Mattke Antriebstechnik Leinenweberstraße 12 D-79108 Freiburg Germany
Test body	0948
Number of certificate	TÜV-A 11ATEX0006X
Certification	EN60079-0, EN60079-1, EU- Richtlinie 94/9/EG, Anhang III
Ex-certification	II 2G Ex d IIC T5 Gb
Installation place	Ex-area zone 1, 2
Specification	
Nominal voltage	24 V DC
Max. continuous current by Temperature range T6	2 A
Max. continuous torque	75 mNm
Max. power	53 W
Max. dissipation	11 W
No load speed by 24 V	4700 rpm
Speed range	1 – 4700 rpm
Length of the cable	10 m
External compensation of potential	wires: 4 mm ² flexible 6 mm ² single-wire
Protective class according EN60529	IP54
Operation temperature range	-20 ... +45 °C

Table 2

Technical data Ex-motor

Parameter	mzr-2509 Ex	mzr-2909 Ex	mzr-4609 Ex	mzr-7209 Ex
Max. Peak current	800 mA	800 mA	900 mA	2000 mA
Max. Continuous current	600 mA	600 mA	700 mA	1800 mA
max. Acceleration	550 U/s ²	550 U/s ²	550 U/s ²	550 U/s ²

Table 3 Programming current parameters for mzr-2509 Ex, mzr-2909 Ex, mzr-4609 Ex and mzr-7209 Ex

Wire	Function
brown	motor +
blue	motor -
yellow/green	screening / PE
red	V _{cc} (5 VDC)
blue	SGND
pink	channel A neg.
grey	channel A
yellow	channel B neg.
green	channel B
brown	channel O neg. (index)
white	channel O (index)

table 4 Pin configuration motor cable (10 Lead of cable) valid as of September 2012

Wire	Function
white	motor +
brown	motor -
yellow/green	screening / PE
red	V _{cc} (5 VDC)
blue	SGND
pink	channel A neg.
grey	channel A
violet	channel B neg.
black	channel B
rot/blue	channel I neg. (index)
pink/grey	channel I (index)

Table 5 Pin configuration motor cable (10 Lead of cable) valid until September 2012

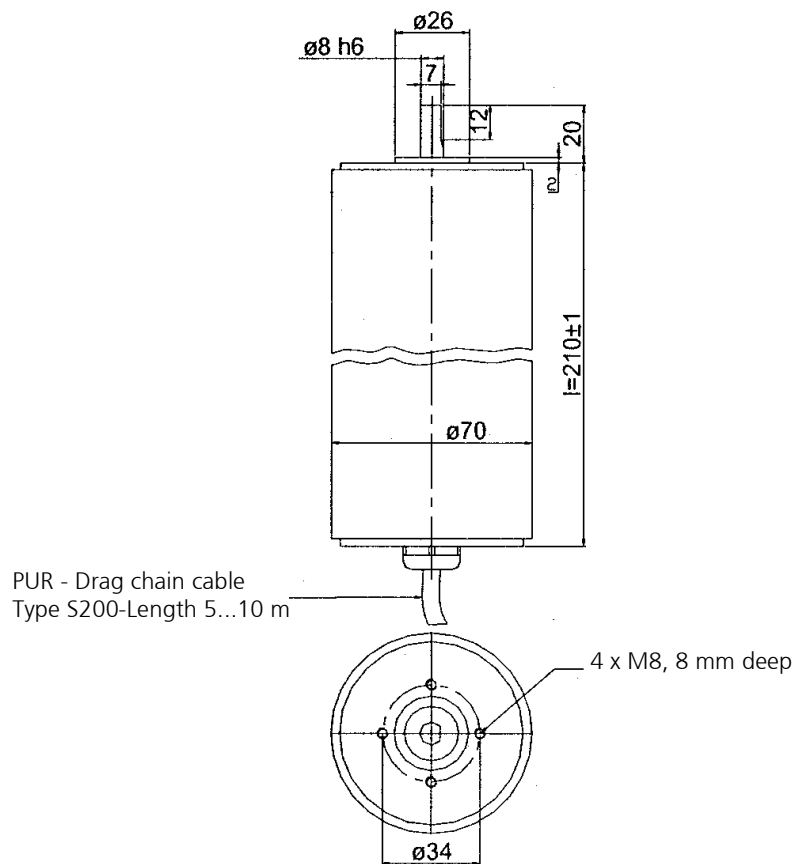

Figure 9

Measurements of the motor (standard cable length 10 m)

The motor is delivered with a digital encoder type HEDL5540 with line driver and 500 counts per revolution.

Encoder	
Max. voltage V_{cc}	5 VDC \pm 10 %
Number of channels	3 (A, B, O)
Counts per revolution and channel	500
Output signal at $V_{cc} = 5$ VDC	EIA standard RS422 used driver: DS26LS31
Output current	max. 20 mA
Phase shift Φ (nominal)	90°
Operating temperature range	0 ... +40°C

Table 6

Technical data encoder

1.9 Technical data of the alternativ brushless DC Ex-motor (X2 version)

The micro annular gear pumps m zr-6359X2 Ex and m zr-7259X2 Ex are equipped with a alternativ explosion-proof brushless DC-motor. The parameters of the motor are described in Table 2. The speed of the motor can be controlled with the internal motion controller. One of the motor's features is a highly dynamic behavior. For operation it is recommended to use a power source of 24 V (with a power rating of 5 A).

The motor of the pumps is corresponding to the applicable EC standards. The confirmations according to EC 94/9/EG as well as of EC conformity are given.

Measurements	
Diameter of motor casing	70 mm
Length of motor casing	285 mm
Weight	approx. 2,3 kg (without cable)
General data	
Type	EXR-32.24-MC3-L10
Manufacturer	Edelweiss Actuators Srl, Via Padergnone 21 I-24050 Zanika BG Italy
Distribution / Service	Mattke Antriebstechnik Leinenweberstraße 12 D-79108 Freiburg Germany
Test body	0948
Number of certificate	TÜV-A 11ATEX0006X
Certification	EN60079-0, EN60079-1, EU-Richtlinie 94/9/EG, Anhang III
Ex-certification	II 2G Ex d IIC T5 Gb
Installation place	Ex-area zone 1, 2
Specification	
Nominal voltage	24 V DC
Max. continuous current by Temperature range T5	2 A
Max. continuous torque	85 mNm
Max. power	53 W
Max. dissipation	11 W
No load speed by 24 V	4200 rpm
Speed range	1 – 4000 rpm
Length of the cable	10 m
External compensation of potential	wires: 4 mm ² flexible 6 mm ² single-wire
Protective class according EN60529	IP54
Operation temperature range	-20 ... +40 °C

table 7

Technical data Ex-motor for m zr-2509X2 Ex, m zr-2909X2 Ex, m zr-4609X2 Ex und m zr-7209X2 Ex

Parameter	m zr-2509X2 Ex	m zr-2909X2 Ex	m zr-4609X2 Ex	m zr-7209X2 Ex
Max. Peak current	700 mA	700 mA	800 mA	1700 mA
Max. Continuous current	550 mA	550 mA	650 mA	1500 mA
max. Acceleration	500 U/s ²	500 U/s ²	500 U/s ²	500 U/s ²

Tabelle 1

Programming current parameters for m zr-2509X2 Ex, m zr-2909X2 Ex, m zr-4609X2 Ex und m zr-7209X2 Ex

Wire	Function	Cable cross-section
brown	24 VDC	0,5 mm ²
blue	GND	0,5 mm ²
yellow/green	screening / PE	0,5 mm ²
red	3 IN	0,14 mm ²
blue	n.c.	0,14 mm ²
white	Fault out	0,14 mm ²
pink	n.c.	0,14 mm ²
grey	AGND	0,14 mm ²
yellow	RxD / IN CAN_L	0,14 mm ²
green	TxD / IN CAN_H	0,14 mm ²
brown	ANIN	0,14 mm ²

table 8

Pin configuration motor cable (12 Lead of cable)

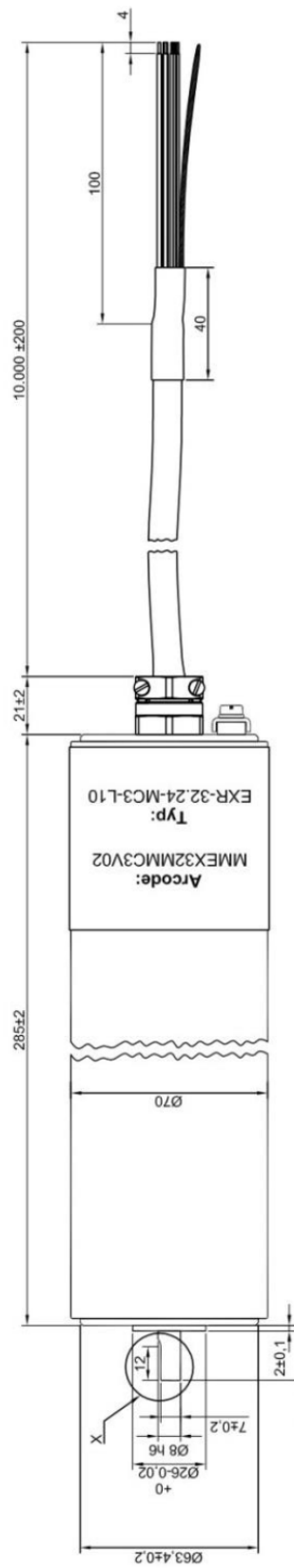





Figure 10 Measurements of the motor (standard cable length 10 m)

2 Safety instructions

Comply with the general safety instructions listed in the safety section as well as with the special safety instructions listed under the other main sections. All legal and corporate safety instructions have to be obeyed.

2.1 Labeling of instructions in the operation manual

The safety instructions listed in this operation manual are specially labeled. It can cause danger for persons, if they are not complied with.

Danger symbol		Non-compliance poses danger for persons.
High voltage symbol		Non-compliance poses danger of electrical shock.
Ex-symbol		These instructions must be complied with in full for explosion-protection.

The type plate mounted on the pump must be complied with and has to be maintained in a clearly readable condition.

Please pay attention to items marked with the following symbols. Pump or system damage is possible if these warnings are ignored.

Warning

Information plates attached directly to the pump head **for example** name of the fluid inlet/outlet, sign with the direction of rotation must be observed and preserved.

2.2 Staff qualification and training

The staff for operation, maintenance, inspection and assembly must evidence appropriate qualifications for these works. Areas of responsibility, competencies and monitoring of the staff must be precisely regulated by the operating company. If the personnel do not have the necessary knowledge, they must be trained and instructed accordingly. If necessary this can be carried out by the manufacturer / supplier on behalf. In addition, the operating company must ensure that the content of this operating manual is fully understood by the personnel.

2.3 Safety conscious work

The safety instructions listed in this operation manual, the applicable national regulations for accident avoidance and all internal working, operating and safety regulations of the operating company must be complied with.

2.4 Safety instructions for the operator

The *surface temperature* of the *actuators* can exceed 60°C (140°F) in *full load*. You might want to *provide protection to avoid accidental contact*, which will cause burns on skin.

The drive should be protected against dust, water vapor condensation, humidity, splash water, aggressive gases and liquids. Please provide for adequate air ventilation and thus cooling of the motor.

Leakage (e.g. from the shaft seal) of dangerous conveyed goods (e.g. explosive, toxic, hot) must be lead away in such a manner that no danger is present for persons and the environment. Legal requirements must be complied with.

The existing protections against contact for the moving parts of the pump (such as for example the coupling) must not be removed during operation.

Take care that all risks resulting from the electric energy are excluded. (For details please refer to the instructions provided by the authorities in charge or your power supplier.)

Warning

Please insure, that the totality of the liquid supply accessories such as tubes, hoses, filters etc. are free from dust or dirt particles. Impurities such as metal, plastic or glass particles may impair or damage the pump leading to its failure.

Warning

Please, operate the pump with a filter featuring 10 µm or smaller pores. It will protect the pump.

2.5 Safety instructions for maintenance, inspection and assembly

The operator must ensure that all maintenance, inspection and assembly is carried out by authorized and qualified personnel, who are sufficiently familiar with this operation manual.

In general, work on the machine should only be implemented when it is at a standstill. The instructions of the manual to shut down the pump must be definitely observed. Pumps or aggregates that convey liquids hazardous to health must be decontaminated. Immediately after operation is completed, all safety and protection equipment must be remounted and restarted.

Before restart of operation, the points listed in the initial start-up section (see section 7) must be observed.

Warning

Do not disassemble the micro annular gear pump in case of malfunction. Contact the service personnel of your distributor or HNP Mikrosysteme immediately for help.

When sending a micro annular gear pump for repair or maintenance the »declaration of liquid contact« of the liquid pumped and the operation statement from section 16 has to be enclosed in the shipment.

2.6 Unauthorized modification and original spare parts

Modification of the pump is only permitted prior to consultation with the manufacturer. Original spare parts and accessories authorized by the manufacturer ensure safety. The use of other parts may abolish the liability for any resulting damage.

2.7 Improper mode of operation

The operation safety of the delivered machine is only ensured by its correct use as per section 1 in this operation manual. The limit settings given in the manual must not be exceeded in any case.

2.8 General safety instructions

Please also obey the following safety notes.



Skilled personnel may only do *mounting* and *initial operation* of micro annular gear pumps.



The pump can achieve *high pressures*. Use only the fluidic connections included in the delivery and be sure, that *fittings* and *tubes* are *permissible* and *specified* for these pressures.



In order to decrease the pressure, provide the system with a *pressure control valve* directing the excess liquid to the storage tank or back to the suction side. In the case of blockage of the pressure side the operating pressure can multiply, this can lead to the damage of downstream components.



If standstill occurs, the liquid in the pump may float in direction of the pressure drop in the pump. If necessary provide *back pressure valves* (see: accessories).



Protect the micro annular gear pump and the electric actuator from *shock* and *impact*.



In standard operation the *rotary shaft seals* used in the micro annular gear pump prevent leakage. Micro annular gear pumps are »technically sealed«, but *not hermetically sealed*, so that gases may escape from the pump or penetrate into the pump.



The *permitted electrical data setting* of the actuators may *not be exceeded*. Notice that especially *the accurate set of polarity* of the supply voltage is required, if not the control unit can be destroyed.

Warning

For the operation of a micro annular gear pump, the use of filters with a pore size of 10 µm or smaller is required.

Warning

The preference state for the integration of the micro annular gear pump is horizontal. To prevent a possible penetration of liquid in the motor, the motor should be preferably assembled above the pump head.

Warning

It is necessary to check the liquid resistance in each individual case and to adapt the seal equipment.

3 Transport and storage

3.1 Shipping pumps and protection measures

The pumps are shipped from the factory in such a manner that they are protected against corrosion and against shocks.

In addition, inlets and outlets are plugged with protective plugs. This measure is necessary to securely prevent foreign bodies from penetrating into the pump's interior.

3.2 Transport damage

To avoid transport damage, the transport packaging must be protected against shocks.

HNP Mikrosysteme guarantees that the shipped goods are in perfect condition at the time of delivery. The pumps must be immediately checked for transport damage once the pumps have been received. If damage is noted, the shipper responsible and the pump manufacturer must be informed immediately.

3.3 Interim storage

The following points must be obeyed for storing the pumps:

- Do not store the pumps in wet or damp rooms
- Protective plugs must be left screwed in
- Store temperature see according section 1.3 of this manual

3.4 Conservation for storage after operation

When the micro annular gear pump operation is stopped for some time period the pump has to be cleaned by flushing. See also chapter 7.6 for decommissioning. When pump is clean it has to be filled with a preserving liquid such as precision mechanic oil or Isopropyl alcohol.

4 Description of the pump

4.1 Principle of the micro annular gear pumps

Micro annular gear pumps are positive displacement pumps. They contain two rotors, bearing slightly eccentrically to each other; an externally toothed internal rotor and an annular, internally toothed external rotor (see figure 11). Due to their cycloid indenting, the rotors remain interlocked at any time, forming during rotation a system of several sealed pumping chambers. As the rotors revolve around their offset axis, the pumping chambers increase on the induction (suction) side and simultaneously decrease on the delivery side of the pump (see figure 12). A homogenous flow is generated between the kidney-like inlet and outlet.

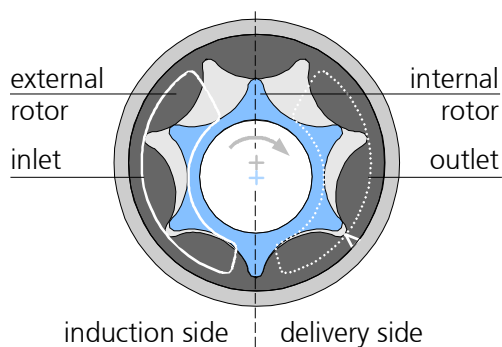

figure 11

Principle of the micro annular gear pump

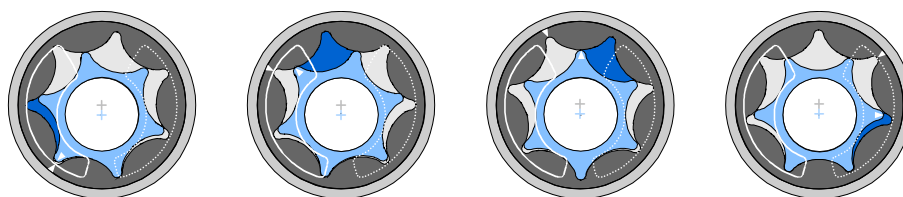

figure 12

Operating principle of the micro annular gear pump

Reciprocating and rotary pumps have a direct allocation to the fed amount of the displacement volume V_g of the pump and its actuator's number of revolutions n . The displacement volume describes the volume, which is theoretically fed with each revolution. The coherence of the flow rate referring to the formula (= volumetric flow rate) Q of the pump is:

$$Q = \eta_{Vol} \cdot V_g \cdot n$$

The volumetric efficiency η_{Vol} describes the coherence of the actual flow rate from the theoretical resulting value. Differences occur according to leaking, as the sealing on the inside of the pump is done over a gap. The volumetric

efficiency is dependent on the liquids and the pressure against which it has to be fed.

Example: The pump m zr-2909 Ex feeds with its displacement volume of 3 μ l with 3000 RPM and a volumetric efficiency of 100 % referring to the above-mentioned formula the flow rate of 9 ml/min. The following table shows the volumetric displacement in dependence to the number of revolutions for a volumetric efficiency of $\eta_{Vol} = 100 \%$.

speed [rpm]	m zr-2509 Ex		m zr-2909 Ex		m zr-4609 Ex		m zr-7209 Ex	
	Q [ml/min]	Q [ml/h]	Q [ml/min]	Q [ml/h]	Q [ml/min]	Q [ml/h]	Q [ml/min]	Q [ml/h]
500	0,75	45	1,5	90	6	360	24	1440
1000	1,5	90	3	180	12	720	48	2880
2000	3	180	6	360	24	1440	96	5760
3000	4,5	270	9	540	36	2160	144	8640
4000	6	360	12	720	72	2880	192	11520

Table 9

Theoretical flow rate of the micro annular gear pump m zr-2509 Ex, m zr-2909 Ex, m zr4609 Ex or m zr-7209 Ex

The pressure, which the pump has to generate, is given by the construction of the fluidic system and the results of the hydrostatic pressure and the hydraulic resistance (given by tubes, contractions etc.).

The viscosity of the pumping liquid has an important influence on the volumetric efficiency. The volumetric efficiency increases with higher viscosity according to the smaller disengagement through the gaps of the pump.

Cavitation is an effect, which can reduce the volumetric efficiency from in a specific ceiling speed. With increasing viscosity (e.g. > 5.000 mPas), this ceiling speed is lower. This is the result of the liquids specified underflow of the steam pressure in the induction port of the pump, in which gases are building up in the pump.

The specific feature of the m zr-pumps is their highly precise design, as well as the guarantee of high accumulator pressure and high accuracy in flow rate and dosage. Therefore, space width and transverse space width of the rotors as well as the interspace to the adjacent case parts lie in the range of just a few micrometers. This precision is at the same time the criteria to achieve a volumetric efficiency in the range of approximately 100 %.

4.2 Construction

The micro annular gear pumps mzs-2509 Ex, mzs-2909 Ex, mzs-4609 Ex and mzs-7209 Ex consist out pump head, coupling assembly and motor with cable gland. The micro annular gear pump has a bracket to the simple fastening.

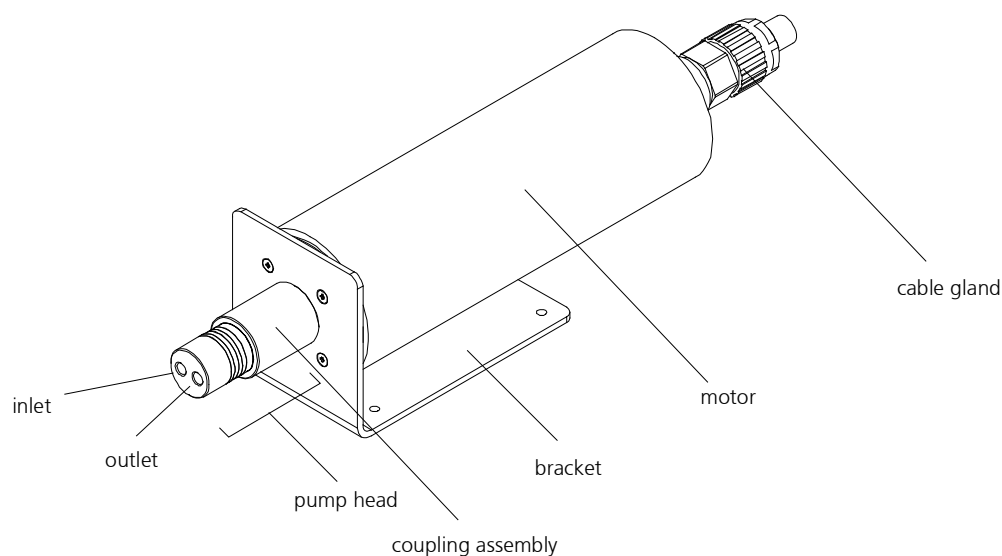

figure 13 Design of the micro annular gear pumps mzs-2909 Ex and mzs-4609 Ex (mzs-7209 Ex similar illustration)

4.3 Materials and liquids

Wetted parts	mzs-2909 Ex, mzs-4609 Ex	mzs-7209 Ex
Pump housing	stainless steel 316 L (1.4404, 1.4435)	stainless steel 316 L (1.4404, 1.4435)
Rotors, shaft, bearing	tungsten carbide Ni-based	tungsten carbide Ni-based
Shaft sealing	graphite-reinforced PTFE, 316L spring	graphite-reinforced PTFE, 316L spring
Static sealing	FKM, optional: EPDM, FFKM	FKM, optional: EPDM, FFKM

table 10 Construction materials of the wetted parts



The liquid resistance of the materials has to be checked and guaranteeing before the operation by the operator.

The liquid resistance has to be checked in every individual case. The feeding of non-lubricant liquids reduces the service life of the micro annular gear pump. This is also true for liquids containing particles.

4.4 Fluidic connectors

	Liquid inlet/outlet	Tubing
mzs-2909 Ex, mzs-4609 Ex	1/4"–28 UNF, front	OD 1/8" plastic tubes or stainless steel tubes (optional outer diameter 1/16")
mzs-7209 Ex	lateral 1/8" NPT internal thread front 1/8" NPT internal thread	tube/hose OD 6 mm

table 11

Liquid supply

The liquid inlet is marked with the letter »S«, the liquid outlet connection with the letter »D«. An arrow indicates the inherent turning direction of the shaft.

For protection against penetrating dust particles and contamination, sealing plugs are inserted into the threads. The sealing plugs have to be removed before the assembly of the fluidic connectors. Please reseal the threads with the cleaned sealing plugs when the fluidic connectors are disassembled.



The assembled fluid connectors have to be checked immediately after bringing the pump into operation. This is also true for service in a half-yearly cycle on tightness and leakage.

5 Modular system

The spectrum of applications of the high performance micro annular gear pump series may be expanded by using different additional modules. The modules allow for special applications, which could otherwise not be accomplished with a standard pump version. The modules may be combined with each other and with almost all available pump heads.

- *Fluidic seal module* prevents possible chemical reactions between the delivered liquid and the surrounding environment
- *Heat insulation module* extends the operating temperature range of the pump by protecting the motor from overheating
- *Heating module* enables to regulate the temperature of the fluid-containing parts of the pump
- *Gas-tight sealed* version: almost hermetically sealed pump, delivered as standard with the high performance mzs-pumps

The configuration of a given pump version should in each case be discussed with consideration to the specific requirements of the application. *Additional* customized modules may be designed on demand.

5.1 Fluidic seal module

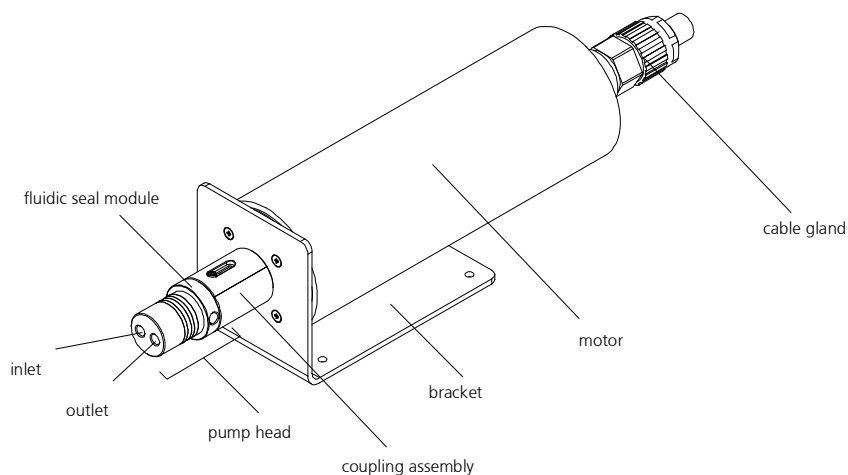

figure 14

Design of the micro annular gear pump mzs-4609 Ex with fluidic seal module

The module can be applied for liquids which tend to react or crystallize in contact with gases such as oxygen or water. The use of a fluidic seal module has to be confirmed with the pump manufacturer.

Functioning of fluidic seal module

Based on the pump design in the rotary shaft seal there is a liquid boundary film where the liquid is in contact with the ambient. Here small amounts of ambient humidity or oxygen can penetrate into the pump getting over the sealing lip. To prevent penetrating molecules from outside into the pump but also hazardous substances coming out of the pump the fluidic seal module was designed.

For this reason a second rotary seal is added to the pump which is located in the fluidic seal module. Between the two rotary seals a fluidic chamber (see figure 15) is formed which is filled with a sealing liquid compatible to the pumped liquid. The fluidic seal module has two ports opposite to each other for filling and degassing. A pressure head can be applied to the sealing liquid to assure a support of the sealing function. In certain cases the sealing can be flushed.

The sealing liquid will dilute the pumping liquid during operation with a dilution ratio of approx. 1:1,000,000. The sealing liquid has to be compatible with the delivered liquid and has to be determined in interdependence. A cartridge can be used as a reservoir and is sufficient at maximum flow for one month in most cases.

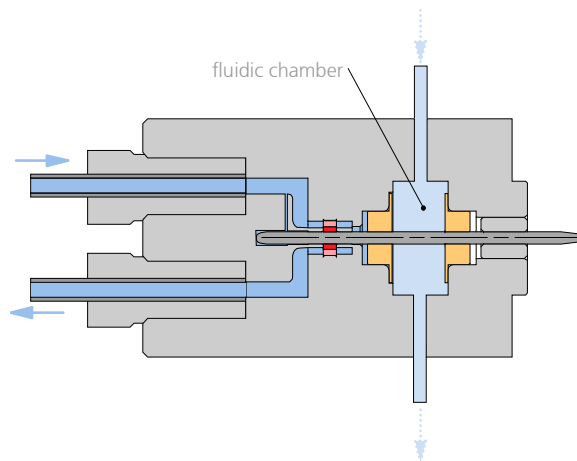

figure 15

Sectional view of the micro annular gear pump with fluidic seal module

Operation with fluidic seal module

The selected *sealing liquid* has to be *compatible* with the *delivered liquid*. The customer is in charge of the correct selection.

The filling procedure through the port has to be realized carefully. The ports have a 1/4"-28 UNF thread. They are displaced to realize a better degassing of the seal chamber also in a horizontal direction. The filling of the sealing liquid starts with the lower level port. The filling of the fluidic seal module continues until no bubbles can be seen on the outlet port side. When the liquid is free of

bubbles the outlet port has to be closed by vent screw. To fill the chamber a cartridge or syringe with an appropriate thread 1/4"-28 UNF can be used.

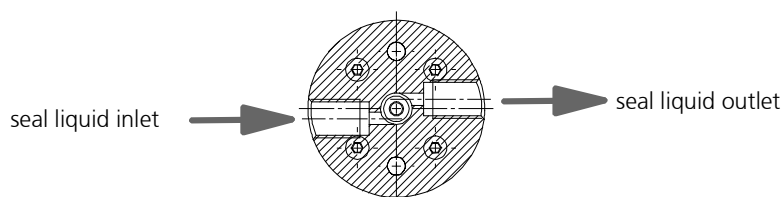

figure 16

Sectional view of the fluidic seal module



Please note that the cartridge or syringe has to be filled up always with sufficient sealing liquid to avoid air or moisture contact.



In case of installation within explosion proof areas a level control for the reservoir of the seal liquid is necessary to avoid dry running of the pump. If the fluidic seal module is empty the pump must shut down immediately.

If a different installation is selected than the standard installation (e.g. pump marking horizontal readable) it is possible to exchange the seal liquid inlet port and outlet port.

The cartridge always has to be assembled in a vertical way to guarantee that the liquid is gas free and can refill the sealing chamber.

5.2 Heat insulation modul

The heat insulation module enables to deliver hot liquids up to temperatures of 130° C (266 °C). It comprises thermally insulating coupling components made of plastic (PEEK) located between the pump and the drive. The drive should not be exposed to overheating. For this reason the heat transfer from the pump to the drive should be limited. An additional thermal barrier is provided by the plastic motor housing. If the surrounding temperature rises, the pump is working over a longer period or the manipulated liquid features a high temperature, convection cooling of the motor is recommended.



Earth the pump head additionally at the corresponding terminal clamp.



The pump carries the changed identification with the non insulating coupling components and the higher temperature:

CE  **II 2G c IIC T3 X**

Description of the single symbols:

-  Equipment meets the requirements of the RL 94/9/EG
- II** Equipment of the group of equipment II („Non-mining industry“)
- 2G** Equipment of the category 2, intended for the employment in zone 1 (explosion endangerment by inflammable gases, steams or nebulas), can be used also in zone 2
- c** As explosion prevention measure the ignition enclosure was converted „constructional security“(c) according to EN 13463-5.
- IIC** The equipment fulfills the requirements for the employment within highly combustible ranges, within which the explosion endangerment can be due to materials of the explosion group IIC (like e.g. hydrocarbons).
- T3** The equipment fulfils the requirements to that temperature class T3.
- X** For the safe employment of the equipment within highly combustible ranges special conditions are to be considered.

5.3 Fluidic heating- and cooling module

The fluidic heating and cooling module permits active heating or cooling of the pump head in the operating temperature range from -20 °C (-4 °F) to a maximum of 150 °C (266 °F). The module consists of a double casing covering the pump head and a thermoelectric couple type K, whose mode of integration varies depending on the pump size. Oil, water, superheated steam or adapted cooling liquids may be used as thermal liquids. If you are not sure, which heat transfer liquid is the best adapted in your case, HNP Mikrosysteme will help you find the suitable one. The thermal liquid ports $2 \times \text{G}1/8''$ are displaced by 45° . The inlet for the heat transfer liquid is situated at the back (beveled) and the outlet is in the front (see figure 17).

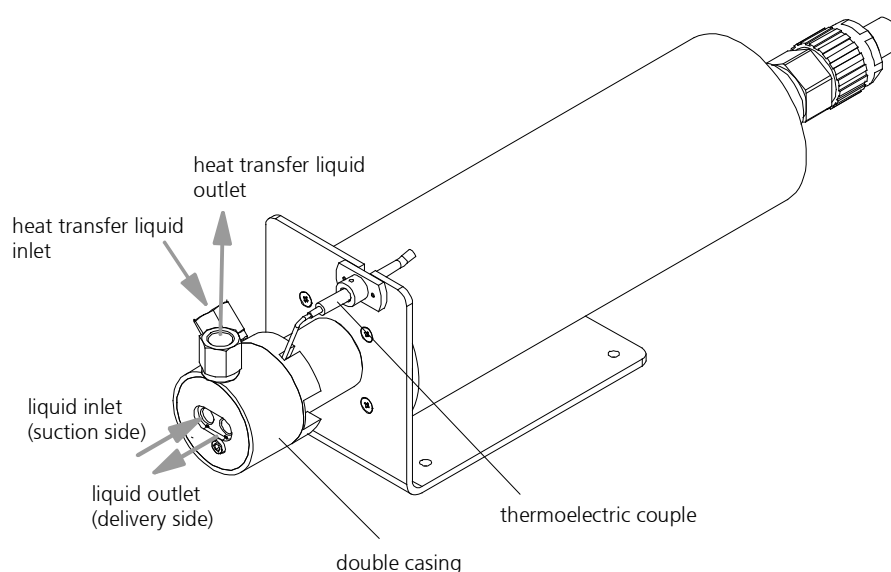

figure 17

Micro annular gear pump with integrated fluidic heating- and cooling module (example of m zr-4609 EX)



The heating and cooling module is approved for use in EEx areas



Earth the pump head additionally at the corresponding terminal clamp.

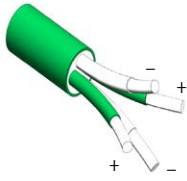

Before connecting the liquid supply, please observe the following technical data! The maximal pressure of the heat transfer liquid should not exceed 20 bar.

Thermal element		IEC 584.3 identification
Type	Thermocoax: 4ABAo15/35mm/TVD5 0/4ABAB40T/12m – ATEX EExia IIC T6	
Thermal element	2 Thermal elements Typ K (NiCr-Ni; Chromel-Alumel)	
Temperature measuring range	-100 to +400 °C (-148 to 752 °F)	
Diameter of the sensing device	approx. 1.5 mm	
Material	V4A (1.4541)	
Length compensating circuit	12 m	
Diameter compensating circuit	4 mm	

Double jacket	mzr-2909 Ex	mzr-4609 Ex	mzr-7209 Ex
Length	34.25 mm	37.0 mm	37.5 mm
Diameter	42.4 mm	42.4 mm	48.3 mm
Double jacket material	stainless steel 316L	stainless steel 316L	stainless steel 316L
Inlet	2xG1/8" (45° distance)	2xG1/8" (45° distance)	2xG1/8" (45° distance)
Operating temperature range	-20 to +150 °C (-4 to +266 °F)	-20 to +150 °C (-4 to +266 °F)	-20 to +150 °C (-4 to +266 °F)
Max. pressure	max. 20 bar	max. 20 bar	max. 20 bar
Flow rate	max. 0.5 l/min	max. 0.5 l/min	max. 0.5 l/min

table 12

Technical data of the heating and cooling module



The pump carries the changed identification with the non insulating coupling components and the higher temperature:

CE  **II 2G c IIC T3 X**

Description of the single symbols:

-  Equipment meets the requirements of the RL 94/9/EG
- II** Equipment of the group of equipment II („Non-mining industry“)
- 2G** Equipment of the category 2, intended for the employment in zone 1 (explosion endangerment by inflammable gases, steams or nebulas), can be used also in zone 2
- c** As explosion prevention measure the ignition enclosure was converted „constructional security“(c) according to EN 13463-5.
- IIC** The equipment fulfills the requirements for the employment within highly combustible ranges, within which the explosion endangerment can be due to materials of the explosion group IIC (like e.g. hydrocarbons).

- T3** The equipment fulfils the requirements to that temperature class T3.
- X** For the safe employment of the equipment within highly combustible ranges special conditions are to be considered.

5.3.1 Construction materials of heating- and cooling module

Wetted parts	mzs-2909 Ex, mzs-4609 Ex	mzs-7209 Ex
Pump case material	stainless steel 316L (1.4404)	stainless steel 316L (1.4404, 1.4435)

table 13

Construction materials of the wetted parts



The resistance of the construction materials to the delivered liquids should be verified by the operator for each individual application of the heating and cooling module.

The chemical resistance of seals in each individual must be verified by the operator.

5.4 Gas-tight seal module

Micro annular gear pumps are „technical tight“, but not hermetical tight. That means there is a small possibility of gas or liquid coming out from inside of the pump or also penetrating into the pump between the inner plates of the structure. These plates have a super finish surface so that they are tight when layered over each other.

For the Ex-pump additional O-rings are mounted between the plates to increase the safety of thightness. With the gas-tight module and the fluidic seal module micro annular gear pumps are nearly hermetical tight.

The micro annular gear pumps mzs-2909 Ex, mzs-4609 Ex and mzs-7209 Ex will be delivered in a gas-tight version in every case.

6 Mounting / Installation

6.1 Check before installation

Inspect pumps for possible shipment damage.

Verify the following points to ensure the pump head is correct for your application (see section 3.2).

- Viscosity range of pumping liquid
- Displacement volume
- Flow rate



If there is a difference between the pump you need and the pump supplied, please contact your distributor or HNP Mikrosysteme directly. In this case do not start operation of the pump without checking with HNP Mikrosysteme.



You must check not only the type of protection of the pump, but also the type of protection of all attached components. The nameplates of the individual components are important. The type of protection for the component with the lowest category always applies for the operation of all components in hazardous areas.

6.2 Details place of operation

Pay attention to the place of operation, that you need an installation location for service and enough room for maintenance. The pump should be installed and reinstalled without problems.



The place of operation mustn't be wet or damp. Don't install the pump in aggressive atmosphere!

6.3 Mounting of the micro annular gear pump

For the mounting of the micro annular gear pump there is a mounting angle to be fastened with four stainless steel M4 screws. The preferred mounting direction of the pump is horizontal. For vertical mounting the preferred direction is where the motor is above the pump head.

To prevent a possible penetration of the motor with escaping liquid, the drive should be preferably assembled vertically over the pump head.



When mounting the motor, insulating elements must not be inserted between the pump head and the motor. The connecting screws between pump and motor must be made out of electrically conductive material (e.g. stainless steel).

Warning

Take care at the mounting of the micro annular gear pump that in the fault case leaking liquid cannot get into the motor or the control unit.



Take caution measures in the case of a leak so, that damage to adjacent facilities and the ambient environment are avoided.



Never install a pump in a small installation location without sufficient ventilation as the motor will be poorly cooled and can overheat.

The actuators must be protected against *moisture, dust and perspiration*.

6.4 Electrical Connections



The electrical connection of the motors must be implemented according to VDE directives by skilled personnel. The operation manual supplied with the motors must also be complied with.



Earth the motor using the terminal provided. Earth the pump head with heating module additionally at the corresponding terminal clamp.

6.5 Assembly instruction for tubing and accessories

Particles or soiling can block or impair the function of the micro annular gear pump.

Warning

Please check that all wetted parts of the fluidic system are clean. Clean these parts in case before mounting the pump.

Please check whether there are swarfs in the screw connections, pollution remaining in reservoirs or soiling in valves, pipe work or filters.

Assembly of the tubing and piping system

1. Please cut the tubing rectangular with a hose cutter.
2. If metal pipes are used an intensive cleaning procedure is necessary. After machining the pipes have to be cleaned and flushed very carefully. Smallest swarfs within the fluidic system can cause failure of the micro annular gear pump.
3. Connect the fittings with the tubing respectively the pipe work according to the attached installation instruction.
4. In the next step seal the pipe fittings at the suction side and discharge side of the pump head with PTFE tape. This is only valid for 1/8" NPT inside thread.
5. The thread of the fitting should be wrapped with 2-3 layers of PTFE tape and screwed in the NPT thread (see table 15). First manually, then tightened with 1/2 to 3/4 wrench turns.

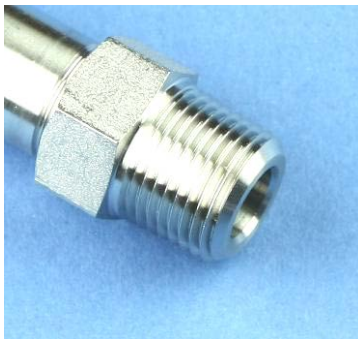

Clean the internal and external screw threads leaving no residues.

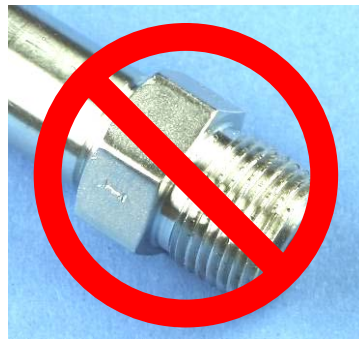

Make sure the internal and external screw threads are not dented or deformed.



Wrap the PTFE tape around the screw thread clockwise beginning with the second pitch of screw thread..



The PTFE tape should be wrapped tightly around the screw thread approx. two times (720°).



Cut the PTFE tape off and wind the end of the tape tightly around the screw thread.



The PTFE tape should not stick out over screw thread because pieces can be cut off and get into the system.

table 14

Use of PTFE Tape



Please note that the correct assembly of tubes respectively pipes with the pump head is a necessary condition to secure the right direction of flow. When you want to operate the pump in reverse direction please contact HNP Mikrosysteme since this is not possible in any application.

6. The suction line should be installed ascending to the pump for better degassing. The suction line should be designed as short as possible. The inner diameter of the suction line should be large to guarantee good priming of the liquid. At the planning of the pipe system take care of possibilities for degassing.
7. Operate the micro annular gear pump always with a filter with a pore size of 10 µm or smaller. The filter prevents that particles or solids penetrate into the pump what can cause major damage.
8. Avoid dry running of the pump. Make sure that the liquid flow is not interrupted.

Warning

Dry running of a micro annular gear pump can *damage* bearings and dynamic seals especially. A short term dry running at the start-up of the pump does not cause problems.

Warning

The pump is equipped with a dynamic seal and a direct drive. Therefore the pump is not hermetic from a technical point of view. That's why it is periodically necessary to check the pump regarding leakage.



Please check that all pipes, fittings and screw fittings are tight.

If there is leakage on the suction side it is possible that air penetrates into the pump. In this case priming will be difficult. At the discharge side the liquid comes out of the pump. Dry running causes the pump to heat up.



If the pump will be operated within an explosion proof area a check valve right must be integrated in the pressure line behind the liquid outlet port of the pump. The check valve has to prevent that the pump empties during shut-down time.

Behind the discharge port the discharge pipe should be installed ascending..



In case the pump operates against a closed system a safety valve has to be installed in the discharge pipe to release pressure. In this case the return flow pipe must go back to the reservoir and not directly to the suction line.

6.6 Filter selection and use

In majority of cases it is recommended to integrate a filter on the suction side of the micro annular gear pump to ensure its secure operation. The recommended filter pores or mesh size should not exceed 10 µm. The penetration of particles or swarf that could cause a blockage or damage to the pump can only be avoided by using an adapted filter.

HNP Mikrosysteme offers a choice of standard filters covering a broad spectrum of applications. You may count on our assistance for the selection of the most suitable one.

In order to select the best adapted filter, such operating parameters as flow rate, viscosity and degree of pollution of the liquid will be needed. An increase in at least one of the mentioned terms will require the use of a bigger filtering element or the pressurization of the delivered liquid. In case no suitable filter for high viscosity liquid can be found, it is possible to use a filter with slightly larger pore size. Prior discussion with HNP Mikrosysteme is here recommended. A filter with larger pores is still better than no filter at all. Alternatively an already filtered liquid may be used.

Warning

Because filters have a large internal volume, it is recommended to fill in the filter and the suction tube with already filtered liquid in order to avoid a longer dry operation of the pump during the startup.

Warning

Please control regularly the filtering elements for pollution. Cleanse regularly the filter or replace it with a new one. A polluted filter may considerably decrease the volumetric efficiency of a pump. Furthermore, because of the cavitation effects dosage imprecision and even pump damage may occur.

Warning

A too small filter (too little filtering surface) may considerably decrease the volumetric efficiency of the micro annular gear pump. What is more, because of the cavitation effects dosage imprecision and even pump damage may occur.

6.7 Requirements for motor controller

To operate a micro annular gear pump mzr-2509 Ex, mzr-2909 Ex, mzr-4609 Ex or mzr-7209 Ex a motion controller is necessary.

Motion controller			
Power supply	U_B	24	V
Max. continuous current	I_{dauer}	1800	mA
Max. peak current	I_{max}	2000	mA
Velocity range		1...4700	rpm
Operation modes		IxR, Encoder	
Encoder			
Max. voltage	V_{cc}	$5 \pm 10 \%$	VDC
Number of channels		2 (channel A, channel B)	
Counts per revolution and channel		500	counts/turn
Output signal at $V_{cc} = 5$ VDC		EIA Standard RS422 Driver: DS26LS31	
Output current		max. 20	mA
Phase shift Φ (nominal)		90°	

Table 15

Technical data motor controller

The mounting place of the motor controller has to be outside of the Ex-area.



Check for correct polarity. False connection may cause severe malfunction or will even destroy the electronic of encoder or motion controller.



For operation of the motor controller current overload has to be avoided, because the motor or the internal encoder will be damaged otherwise.

Optionally the micro annular gear pump mzr-2509 Ex, mzr-2909 Ex, mzr-4609 Ex and mzr-7209 Ex can be delivered with the controller S-HD-KL together with connection board.

To operate a micro annular gear pump only an authorised control module of HNP Mikrosysteme may be used.

6.8 Operation with motion controller S-HD-KL

The mounting place of the motor controller S-HD-KL has to be outside of the Ex-area.

The controller S-HD-KL controls the number of revolutions to achieve a constant flow rate or positions the motor for precise dosage volumes. Values can be set with the help of a potentiometer or with the external control signal 0-10 V. Second a serial interface allows the control of precise feeding and dosing tasks by an external PC. Included in the delivery volume are diskettes with a Windows® based software. The software enables the operator to manage dosing tasks by defining dosing data. A zero modem cable is included in the delivery volume to connect the pump controller S-HD-KL with a PC.

Controller S-HD-KL			
Type of control unit		4-Q servo amplifier	
Nominal voltage	U	24	V
Power supply	U _B	12 - 30	V
Residual ripple		≤ 2 %	
Nominal voltage	U	24	V
Power supply	U _B	12 - 30	V
Max. continuous output current	I _{continuous}	1800*)	mA
Max. peak output current	I _{max}	2000*)	mA
Speed range		10...4700*)	rpm
Input No. 1	input resistance	5	kΩ
Nominal analog speed	voltage range	± 10	V
Nominal digital speed	PWM signal	low 0...0.5 / high 4...30	V
	frequency range	100...2000	Hz
Input/output No. 2 (programmable)	Error signaling	max. U _B / 30 mA	
	no error	switched to GND	
	programmed as input	low 0...0.5 / high 3,5... U _B	V
Input No. 3, 4, 5	TTL - logic level	low 0...0.5 / high 3,5...30	V
	PLC - logic level	low 0...7 / high 12,5...30	V
Program memory		6,6	kBytes

*) Values limited in the control unit with corresponding software

Table 16

Technical data controller S-HD-KL

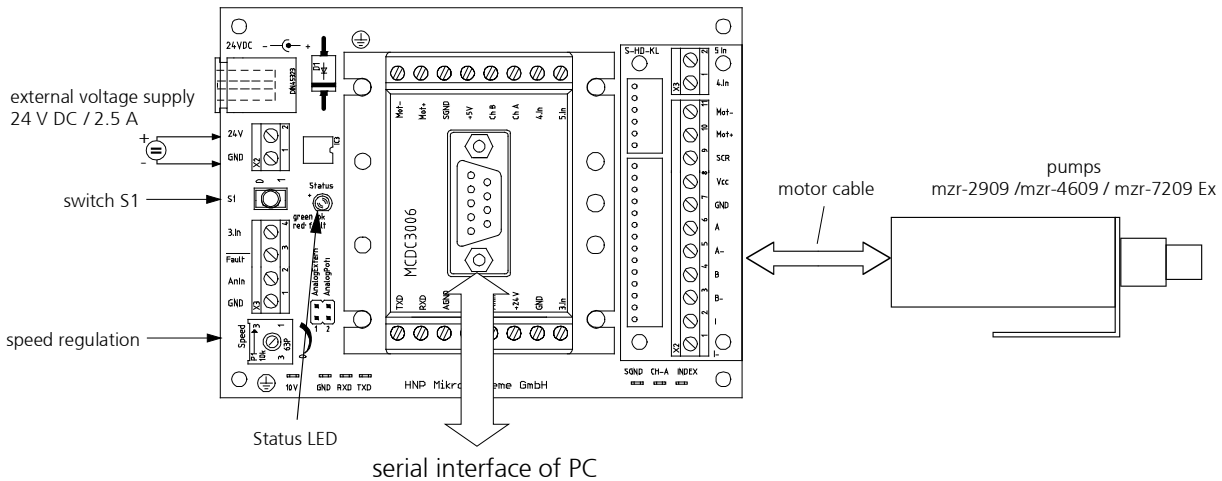

Figure 18 Connection schema controller S-HD-KL

The connection board is helpful for bringing into service of the micro annular gear pump easily. It comprises the following interfaces:

- the possibility to connect the voltage supply to the delivered DIN socket
- the possibility to connect the voltage supply with screw clamps
- a 10-pole connector assembly for the motor cable
- speed set with potentiometer
- analog voltage signal 0-10 V for speed control at the screw clamps
- 9-pole connection plug for the RS-232 interface
- error output with status LED, programmable also as trigger input with screw connections
- tumbler switch S1 for the connection of digital input No. 3 of the motor control unit
- screw clamps for the connection of digital inputs No. 3, 4, 5 of the motor control unit

Initial operation procedure

1. Connect the motor cable with the board S-HD-KL. Colour settings of wires see Table 18.

Pin controller S-HD-KL	Function
white	motor +
brown	motor -
yellow/green	screening / PE
red	V _{cc} (5 VDC)
blue	SGND
pink	channel A neg.
grey	channel A
violet	channel B neg.
black	channel B
rot/blue	channel I neg. (index) (not in used)
pink/grey	channel I (index) (not in used)

Table 17 Pin configuration motor cable adapter (10 Lead of cable) from motor to controller S-HD-KL (8 Lead of cable see 1.8)

2. Connect the RS-232 connector of the MCDC2805 with a free serial interface of a PC. Apply the 9-pin *zero-modem cable*, included in the delivery volume.
3. Turn the potentiometer on the S-HD-KL to zero position by shifting clockwise to the right stop.
4. Connect the voltage supply 24 VDC. This can be done with the integrated DIN connector or alternatively the 2-pole screw clamp (24 V = »+«; GND = »-«). Pay attention to the correct polarity.



Check for *correct polarity*. False connecting may cause severe malfunction or even destroy the electronic of the control unit.



The mounting place of the motion controller is intended for use outside of the hazardous areas only.

Explanation:

- It is possible to adjust speed of the micro annular gear pump with the potentiometer without the need to connect the serial interface.
 - With the analog nominal value input (connection clamps »AnIN« and »GND«) it is possible to adjust speed of the pump with a standard signal 0-10°V. For this purpose it is necessary to plug the jumper on the S-HD-KL control unit from the »AnalogPoti« to the »AnalogExtern«. The serial interface does not need to be connected.
 - In case of an overcurrent error the green status LED on the S-HD-KL control unit turns red
 - The standard programs memorized in the motor control unit may be started with the tumbler switch S1.
5. Install the software »Motion Manager« described in the next chapter.

6.9 Connection of the micro annular gear pump with S-G05

In order to operate the pump a supplementary source of 24 VDC will be required. The ampacity of the voltage source should amount to around 4 A for the micro annular pumps m zr-2509X2 Ex, m zr-2909X2 Ex and m zr-4609X2 Ex. The ampacity of the voltage source should amount to around 4 A for the micro annular pump m zr-7209X2 Ex



The mounting place of the motion controller is intended for use outside of the hazardous areas only.

The micro annular gear pump with alternativ brushless DC Ex-motor is connected via the Terminal Box S-G05. This enables an easy startup of the pump due to:

- the possibility to connect the voltage supply with the delivered plug connector J1
- alternative voltage supply via a DIN connector conform with DIN 45323
- separable pump connection "m zr-pump"
- speed set via potentiometer
- analog voltage input 0-10 V and 0 (4)-20 mA for speed control
- change of speed setting mode with a DIP-switch
- 9-pole connection plug for the RS-232 interface
- error output programmable also as trigger input or frequency output
- digital input with a screw connection
- possibility of installation on a 35 mm top hat rail

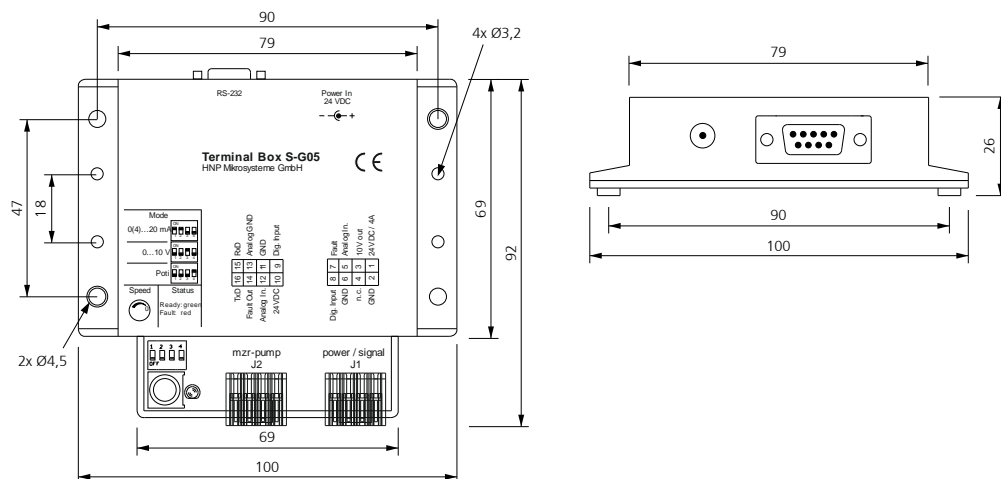

figure 19

Measurements of the Terminal Box S-G05

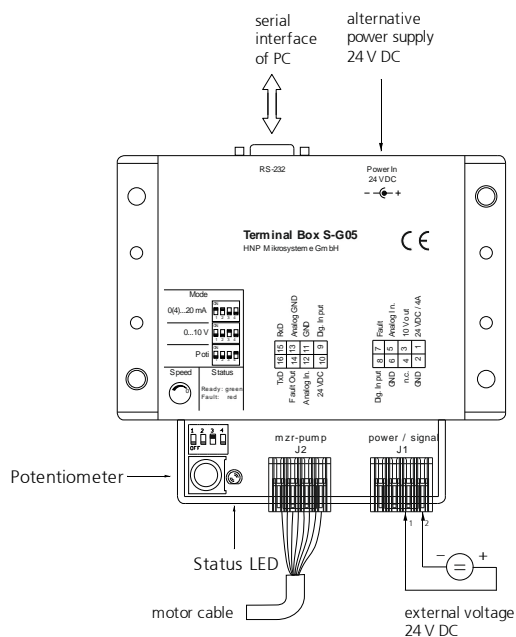

figure 20

Connection of the micro annular gear pump to the power supply

Connector J1 Pin	Function	Labeling Terminal Box
1	Voltage supply	24 VDC / 4 A
2	Ground	GND
3	10 V output voltage	10 V Out
4	not used	n.c.
5	Analog input	Analog In
6	Ground	GND
7	Fault output	Fault
8	Digital Input	Dig. Input

table 18

Connector J1 "power / signal" pin assignment of Terminal Box S-G05

Connector J2 Pin	Function	Wire / Cable cross section	Labeling Terminal Box
9	Digital Input	red / 0,14 mm ²	Dig. Input
10	Voltage supply	brown / 0,5 mm ²	24VDC
11	Ground	blue / 0,5 mm ²	GND
12	Analog input	brown / 0,14 mm ²	Analog In
13	Ground analog input	grey / 0,14 mm ²	Analog GND
14	Fault output	white / 0,14 mm ²	Fault Out
15	RS-232 interface signal reception	yellow / 0,14 mm ²	RxD
16	RS-232 interface signal transmission	green / 0,14 mm ²	TxD

table 19

Connector J2 "mzr-pump" pin assignment configuration between the motor and terminal box S-G05



Installation of the cable wires

- tool: screwdriver blade 2.5 x 0.4 mm
- open the spring clamp with the screwdriver through the side slot
- cable in cable opening place (cable can be used with or without ferrule)
- remove the screwdriver

figure 21

Installation of cable wires in the connectors

LED Status	Definition
green	Power supply to the controller is active, no error
red	Motor error (current limitation or pump blocked)

table 20

LED for status indication

The operating speed of the micro annular gear pump may be set with:

- the potentiometer of the Terminal Box S-G05
- an external voltage signal 0-10 V
- an external, analog current signal 0 (4)-20 mA (without electrical isolation)
- an external potentiometer or
- the RS-232 interface

Individual start up procedures are described in the following points.

6.9.1 Startup with potentiometer

1. Connect the drive with the eight colored wires to the terminal box S-G05. The colors of the corresponding wire connections are described in the table 26.
2. Bring the potentiometer knob to null position by turning it clockwise to the limit stop.
3. Put the DIP-switch to the »Poti« position.
4. Connect the 24 VDC voltage supply to the terminal or to the DIN connector.



Make sure that the polarity of the supplied direct current is correct, otherwise electronics will be damaged.

5. Provide for a steady liquid supply to the pump in order to avoid dry operation.
6. The pump may now be put into operation by turning on the potentiometer knob.

Remarks:

- You may adjust speed of the micro annular gear pump without the need to connect it to the serial interface.
- In case error occurs for example due to motor overload - the green status LED on the Terminal Box S-G05 will turn red.

6.9.2 Startup with external 0-10 V signal

7. Connect the drive with the eight colored wires to the terminal box S-G05. The colors of the corresponding wire connections are described in the table 26.
8. Bring the potentiometer knob to the null position by turning it clockwise to the limit stop.
9. Put the DIP-switch to »0...10 V« position.
10. Connect an external 0-10 V voltage supply to the terminal clamps »AnalogIn« and »GND« to the S-G05. (see figure 13)

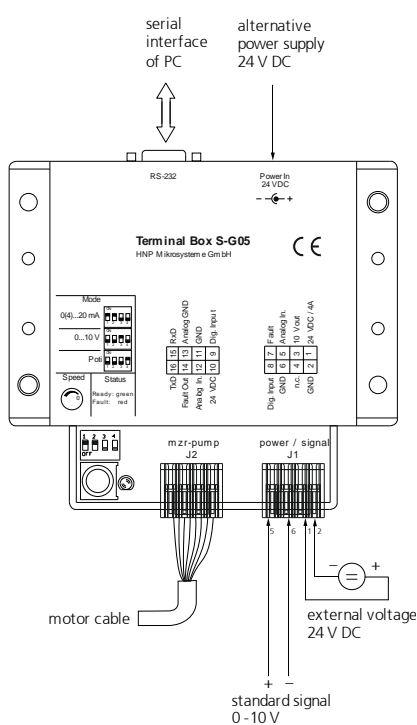

figure 22

Startup with an external 0-10 V voltage signal

11. Provide for a steady liquid supply to the pump in order to avoid dry operation of the device.
12. Connect the 24 VDC voltage supply to the terminal or to the DIN connector.



Make sure that the polarity of the supplied direct current is correct, otherwise electronics will be damaged.



The input circuit at the analog input is layed out as a differential amplifier. If the analog input is "open" there is already a voltage of 2 V. That means in this case that the motor would be turning at a speed of about 2000 rpm. In order to set 0 rpm the input must be connected over a low ohm resistor to the analog ground (AGND) or connected to the AGND-voltage level.

13. The micro annular gear pump may now be put into operation by increasing the external voltage signal. A voltage signal of 0 V corresponds to 0 rpm and 10 V to the maximal programmed speed (see chapter 1.7).

Remarks:

- You may adjust speed of the micro annular gear pump without the need to connect it to the serial interface.
- In case error occurs for example due to the motor overload - the green status LED on the terminal Box S-G05 will turn red.

6.9.3 Startup with an external 0(4)-20 mA current signal



The conversion is done internally without electrical isolation. A potential separation is possible only with a external transformer module.

14. Connect the drive with the eight colored wires to the terminal box S-G05. The colors of the corresponding wire connections are described in the table 26.
15. Bring the potentiometer knob to the zero position by turning it clockwise to the limit stop.
16. Put the DIP-switch to »0(4)...20 mA« position.
17. Connect the external current source to the screw clamps »AnalogIn« and »GND« to the S-G05. (see figure 14).

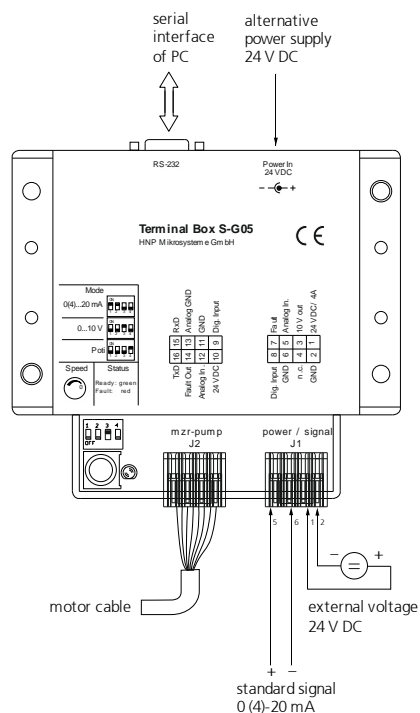

figure 23

Operation via an external 0 (4)-20 mA voltage

18. Provide for a sufficient liquid supply to the pump in order to avoid dry operation of the device.

19. Connect the 24 VDC voltage supply to the screw clamp terminal or to the DIN connector.



Make sure that the polarity of the supplied direct current is correct, otherwise electronics may be damaged.

20. The micro annular gear pump may now be put into operation by increasing the external current signal. 0 mA corresponds to 0 rpm and 20 mA to the maximal programmed speed (see chapter 1.7).

Remarks:

- For operation with the signal 4...20 mA an offset of about 2.1 V should be set by entering the command MAV2170. In order to set the nominal values the micro annular gear pump must be put into operation via the RS-232 interface and start with the » Motion Manager « software. Save the command in the EEPROM with the command EEPSAV (see chapter 8).
- Speed of the micro annular gear pump may be set by sending an external voltage signal without the need to connect the pump to the serial interface.
- In case error occurs for example due to a motor overload - the green status LED on the Terminal Box S-G05 will extinguish and a red one will light up.

6.9.4 Startup with external potentiometer

21. Connect the drive with the eight colored wires to the terminal box S-G05. The colors of the corresponding wire connections are described in the table 26.
22. Bring the internal potentiometer knob to the null position by turning it clockwise to the limit stop.
23. Put the DIP-switch to »0...10 V« position.
24. Connect an external 0-10 V voltage supply to the terminal clamps »AnalogIn«, »10 V« and »GND« to the S-G05.(see figure 13)

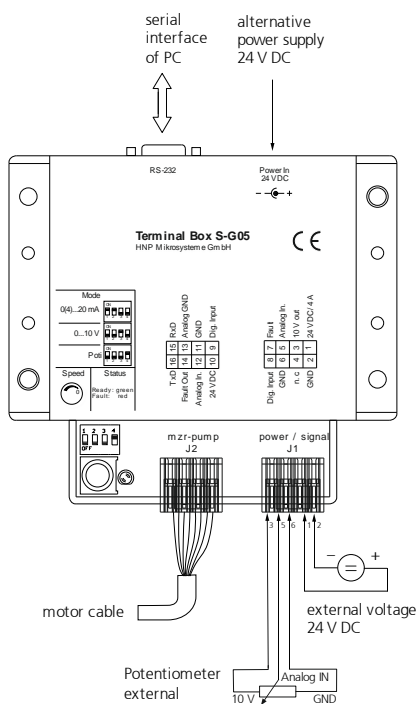

figure 24

Startup with an external potentiometer

25. Provide for a steady liquid supply to the pump in order to avoid dry operation of the device.
26. Connect the 24 VDC voltage supply to the terminal or to the DIN connector.



Make sure that the polarity of the supplied direct current is correct, otherwise electronics will be damaged.



The input circuit at the analog input is laid out as a differential amplifier. If the analog input is "open" there is already a voltage of 2 V. That means in this case that the motor would be turning at a speed of about 2000 rpm. In order to set 0 rpm the input must be connected over a low ohm resistor to the analog ground (AGND) or connected to the AGND-voltage level.

27. The micro annular gear pump may now be put into operation by increasing the external voltage signal. A voltage signal of 0 V corresponds to 0 rpm and 10 V to the maximal programmed speed (see chapter 1.7).

Remarks:

- You may adjust speed of the micro annular gear pump without the need to connect it to the serial interface.
- In case error occurs for example due to the motor overload - the green status LED on the terminal Box S-G05 will turn red.

6.9.5 Startup with the RS-232 interface

28. Connect the drive with the eight colored wires to the S-G05. The colors of the corresponding wire connections are in the table 26.

29. In order to prevent uncontrolled startup of the pump, bring the potentiometer knob to the null position by turning it clockwise to the limit stop.

30. Put the DIP-switch to »Poti« position.

31. Connect the RS-232 interface of the Terminal Box S-G05 with a free serial interface of a PC. Use for that the delivered 9-pole null-modem cable.

32. Now install the delivered software as described in the chapter 8.

33. Connect the 24 VDC voltage supply to the terminal or to the DIN connector.

34. Provide for a steady liquid supply to the pump in order to avoid dry operation of the device.

35. The micro annular gear pump may now be put into operation with the available software (operating mode RS-232 see chapter 8).

Remarks:

- In case error occurs for example due to the motor overload - the green error status LED on the Terminal Box S-G05 will turn red.

6.10 Installation of the software »Motion Manager«

The program »Motion Manager« provides easy operation and configuration of the motor together with an online graphic performance analysis tool. For installation a PC with Windows XP® or Windows 7® is required.

Install the software »Motion Manager« which is included in the delivery CD.

After successful installation start the program »Motion Manager« in the file »Faulhaber Motoren« via Windows® start menu.

If the diskettes of the »Motion Manager« are not delivered, because the software »mzr-pump controller« was included instead, you can download the software from the website <http://www.hnp-mikrosysteme.de>. The latest version can be downloaded in English or German under *Downloads*.

To program a micro annular gear pump motor and controller have to be put into operation. Both units have to be connected with the zero-modem cable.

7 Start up / Shut down

7.1 Prepare for start up

After the liquid supply system had been completed, please check once again the operating conditions of the micro annular gear pump as according to the following points:

- Are the inlet and outlet tubes correctly connected?
- Is the entire liquid supply system clean - that means free of particles, foreign bodies, pollution or swarf?
- Has a filter been installed on the suction side?
- Has a sufficient amount of the right liquid been supplied?
- The pump does not run the risk of a dry operation?
- The entire liquid supply system has been checked for leakage?
- Is it possible to stop the pump by an emergency switch if an unexpected malfunction occurs at the startup?

7.2 First start of a m zr-pump

Switch on power supply. Now the micro annular gear pump can be taken into service by turning at the potentiometer or with help of the pump software (see section 10).

Start the filling in of the pump at low or middle speed (1000 - 3000 rpm).

Warning

Avoid dry operation of the pump. The pump should be filled in before it is put to operation.



If the pump is used in hazardous areas, it must not run dry. The pump and all pipes must be primed and filled with liquid before starting.

7.3 Re-start after dry run



After a short dry run (it is assumed that the pump is not yet damaged), you must ensure that the pump has cooled down to a temperature below its maximally allowed surface temperature. The pump and the pipes must be completely primed and filled.



Re-starting is prohibited after a longer dry run. The pump must be dismantled to check for damage and any damaged parts replaced. The pump may only be operated again after complete priming and filling and the restoration of the earth.

7.4 Operation of the micro annular gear pumps in different temperature ranges

Warning

Micro annular gear pumps are highly precise manufactured devices. *No contamination* may reach the inside of the pump since this can damage the pump. Make sure therefore, that all of the wetted parts are kept absolutely free of dirt, dust or chips since this can affect the function of the pump.



Flow monitoring is also required for operation in hazardous areas to securely prevent dry running. If the flow stops, the pump must be stopped immediately.



During operation in hazardous areas, particular attention must be paid to the heat input in the liquid as well as to the increase of the pump's surface temperature. To avoid temperatures above a critical surface temperature one of the following two measures has to be implemented (see 7.5). If the specified top temperature is exceeded, the pump must stop immediately. For the monitoring the compliance with standard EN 13463-6 has to be respected.



Remove dust deposits regularly from the pump's surface, drive and connection pipes so as to prevent the formation of ignition sources. The cleaning interval must be determined by the level of dust precipitation by the operator.



The fluid connections mounted to the pump have to be checked immediately after putting into service and following to this in a six month cycle on tightness and leakage.



Monitor the operating sound of the pump. If grinding noise occurs, switch off the pump immediately. Check the pump for wear optically. Friction between metallic parts can lead to overheating or formation of sparks.



If the pump is used in hazardous areas, a flow sensor must be installed directly downstream of the pump. The flow sensor must not create a noticeable back pressure in case of damage. If the delivery rate of the pump falls to 20% of the theoretical flow rate, the pump must be stopped immediately.

For operation of the micro annular gear pumps in surroundings with Ex-zone request of temperature range T1-3 and T4 no additional temperature measure is necessary for monitoring.

For operation of the micro annular gear pump in surroundings with Ex-zone request of *temperature range T5 and T6 additional temperature monitoring* is necessary.

7.5 Monitoring of operation in the temperature range T5, T6

Monitoring of surface temperature

Temperature range	T5	T6
Max. surface temperature	60°C	45°C

Table 21 Max. surface temperature

Monitoring liquid temperature on pressure side

Temperature range	T5	T6
Max. liquid temperature	80°C	70°C

Table 22 Maximum liquid temperature

7.6 Flushing procedure after use

After each service the micro annular gear pump should be carefully flushed with a non-corrosive, filtered and particle-free flushing liquid (see table 21 and table 22). During flushing procedure the pump should operate at a speed of about 3000 rpm and if possible against a low pressure (that can be obtained by using a restrictor, a capillary or similar). The flushing liquid must be compatible with the delivered liquid and suitable for solving the remaining liquid rests. Depending on the application for example water, or isopropanol may be used. If you have doubts whether a particular liquid is suitable for this function or not, please ask the manufacturer of the liquid or HNP Mikrosysteme.

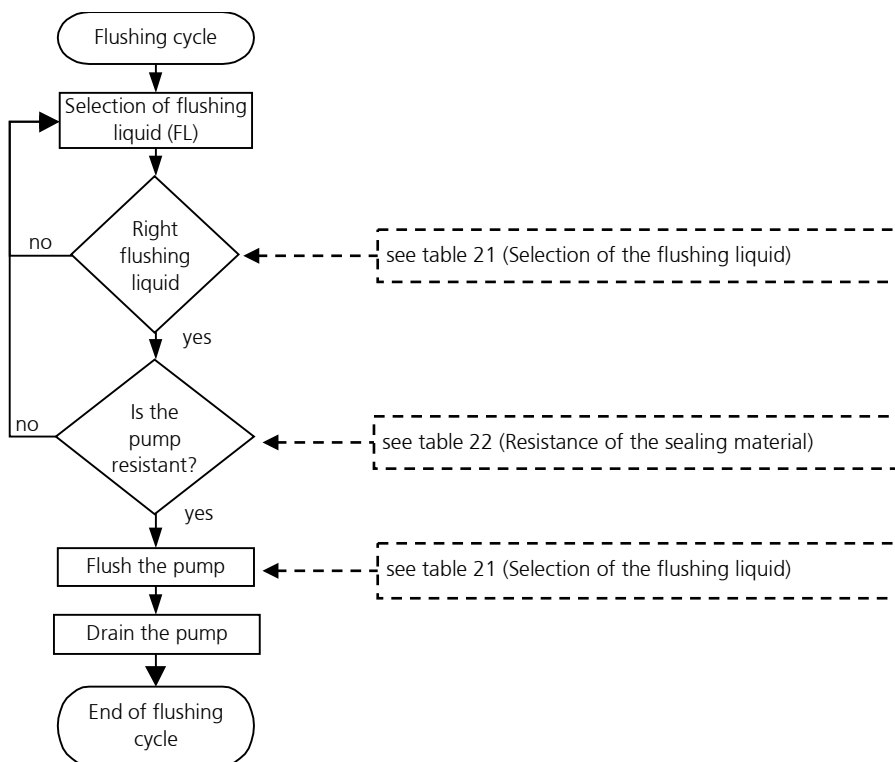

figure 25

Diagram of the flushing procedure

Warning

Liquids that remain in the pump may crystallize, coagulate or lead to corrosion and as a consequence impair the work of the micro annular gear pump.

Warning

Please make sure that the pump components and particularly O-rings and sealing are resistant to the employed flushing liquid. (see table 22).

Warning

The flushing liquid (solvent) and the recommended duration of the flushing procedure depend on the delivered liquid (see table 22). The indicated flushing liquids are simple recommendations and should therefore be checked by the user as to their compatibility and suitability.



Regulations concerning use of substances dangerous to health should be followed!

	Nature of the delivered liquid	Flushing time [min]	Suitable flushing liquid
1	Oils, fats, plastifierrss	15-20	isopropanol, ethanol, acetone, benzine/petroleum ether
2	Solvents (polar + nonpolar)	5-10	isopropanol, ethanol
3	Other organic liquids	10-15	isopropanol , ethanol
4	Refrigerating and cooling agents	15-20	isopropanol, ethanol
5	Neutral water/y solutions	20-25	isopropanol, ethanol
6	Basic solutions	25-30	DI-water (deionized water)
7	Organic acids	30-40	isopropanol, ethanol
8	Weak mineral acids	25-30	DI- water
9	Strong mineral acids	35-45	DI- water
10	Strong oxidizing liquids	35-45	DI- water
11	Paints, varnishes, adhesives	50-60	not specified - for further information please contact HNP Mikrosysteme.

table 23

Selection of the flushing liquid (solvent) and the duration of the flushing procedure depending on the delivered liquid.

Warning

Please make sure that the pump components and particularly O-rings and sealing are resistant to the employed flushing liquid (see table 22).

Flushing liquid	Shaft sealing		O-ring material		
	PTFE (Teflon®), graphite-reinforced	UHMWPE	FKM (Viton®)	EPDM	FFKM
acetone	0	0	3	0	0
benzene	0	3	1	3	0
benzyl alcohol	0	-	0	2	0
butanol	0	-	1	0	0
dimethyl sulfoxide (DMSO)	0	0	3	0	0
ethanol	0	0	0	0	0
isopropanol	0	0	0	0	0
methanol	0	0	2	0	0
methylethylketone (MEK)	0	0	3	1	0
styrene	0	-	1	3	1
toluene	0	1	2	3	0
water	0	0	0	0	0
xylene	0	1	2	3	0
benzine/petroleum ether	0	0	0	3	0
oil / fine mechanics oil	0	0	0	3	0

Legend: 0 ... good suitability 1 ... suitability 2 ... conditional suitability 3 ... labile - ... not specified

table 24

Resistance of the sealing materials depending on the flushing liquid (solvent)

7.7 Shutdown of the micro annular gear pump



Ensure that no hazardous atmosphere is present.

In order to shut down a mzr-pump the following steps should be followed:

- Flush the pump with a filtered and particle-free flushing liquid (solvent) as described in the chapter 7.6.
- After the flushing procedure decrease speed of the pump to 0 rpm
- Fill the pump with a suitable conservation liquid (see chapter 7.7.1)
- Remove the pump from the system (see chapter 7.7.2)

By proceeding as shown in the diagram (see figure 21) you may prepare the pump for a longer standstill.

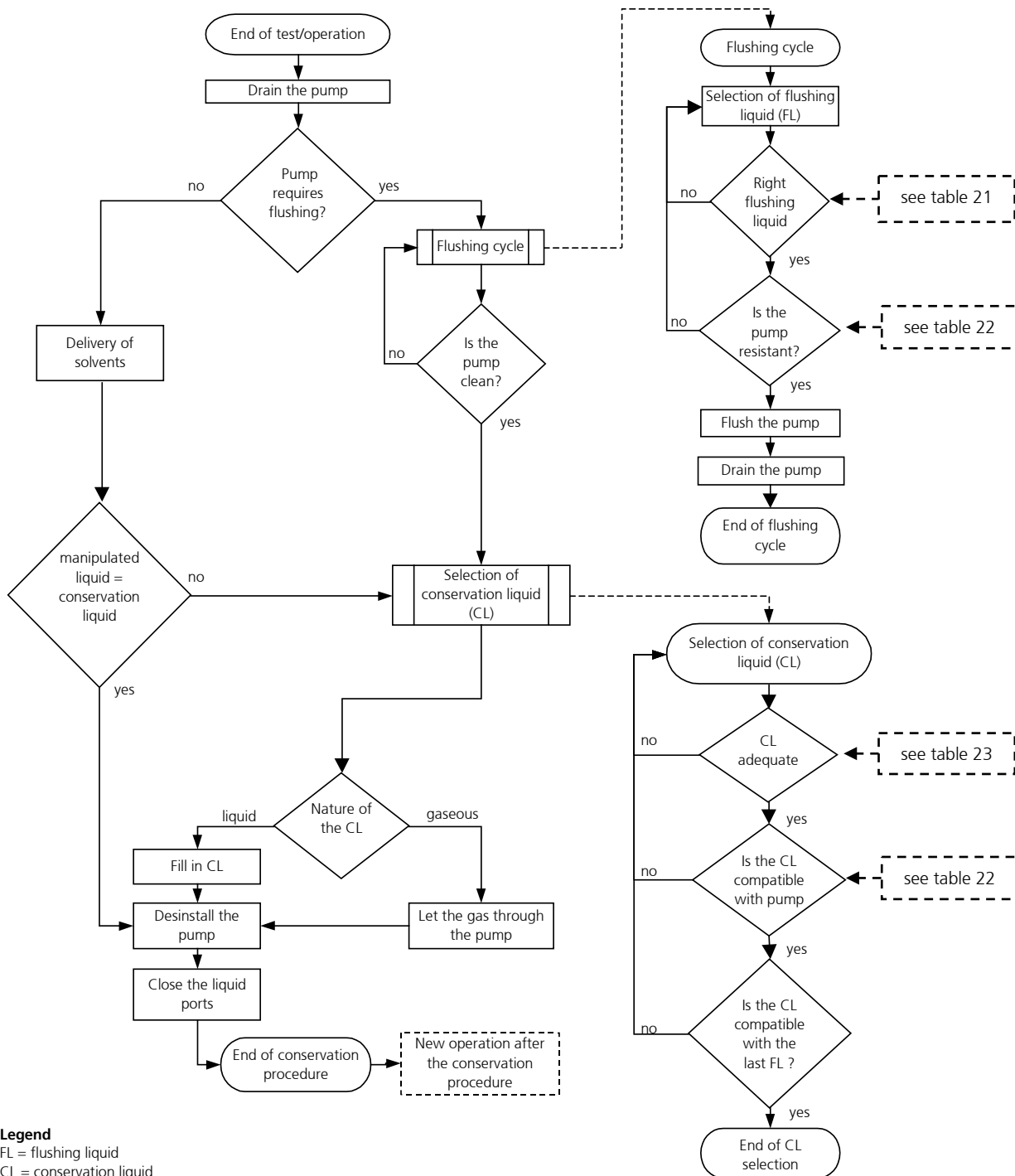

figure 26 Diagram of the shutdown procedure

7.7.1 Conservation

If the micro annular gear pump operates at irregular intervals or for other reasons should be put out of operation for a longer period, it should, after service and flushing procedure (see chapter 7.6), be filled in with a suitable conservation liquid.

The conservation liquid may be selected from the table 23 depending on the duration of the standstill and the resistance of the pump to the manipulated liquid. The indicated conservation liquids are simple recommendations and should therefore be checked by the user as to their compatibility and suitability. The figure 21 presents a diagram of conservation agent selection.

Remark: This diagram is repeated as a part of the figure 20 (shutdown procedure of the micro annular gear pump).

After the cleansing procedure the pump should be filled with a suitable conservation agent. You will find a choice of possible conservation agents in the table 23.

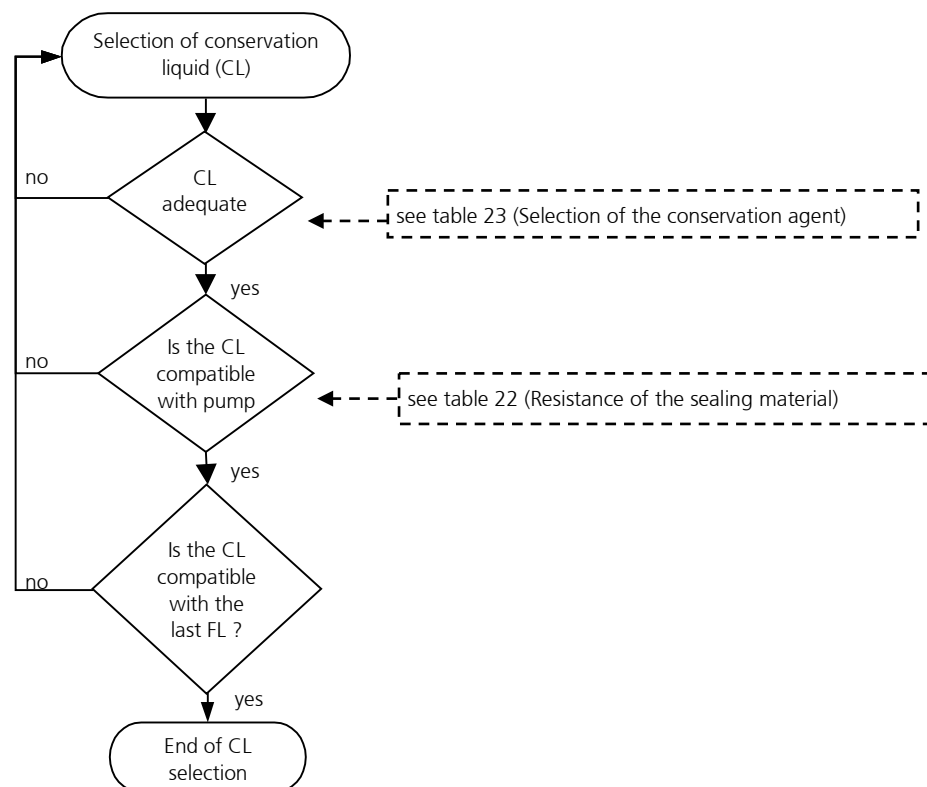

figure 27

Diagram - selection of conservation liquid (CL)

Liquids	Solubility in water	Compatibility with the delivered liquid	Duration of storage	Breakaway torque	Toxicology	Viscosity	Description
isopropanol	+	+	o	o	o	+	solvent for organic compounds, cosmetics, essential oils waxes, and esters, antifreezers, antiseptic agents
acetone	+	+	o	o	o	+	solvent for a number of organic compounds, unlimited solubility in water, dissolves natural and synthetic resins, fats, oils and commonly used plastifiers
ethanol	+	+	o	o	o	+	solvent for organic compounds, fats, oils and resins
DI-water	+	+	-	-	+	+	solvent for many organic and mineral liquids
fine mechanics oil	-	-	+	+	+	+	cleansing and protective action (dissolves fats, tar, rubber or adhesive substances, protects against corrosion).
hydraulic oil	-	-	+	+	+	-	lubricating and preserving properties (<i>Warning</i> : may resinate or deteriorate with time)
nitrogen	-	+	+	+	o	+	is not a solvent, may leave deposits after drying out
air / compressed air		+	+	+	+	+	is not a solvent, may leave deposits after drying out

Legend: + ... good/suitable o ... satisfactory; - ... bad/inadequate

table 25 Selection of the conservation agent

In order to prevent dust particles and foreign bodies from penetrating into the pump or the conservation agent from leaking out, please secure the liquid input and output openings with the delivered protective plugs or screws.

Warning

Water or DI-water should not be used as conservative liquids. They germinate already after a few days and build a biofilm which can later block the pump.

7.7.2 Dismantling of the system

- Put the drive out of operation by turning down speed to 0 rpm and by switching off the voltage supply. Make sure that the procedure described in the chapter 7.6 has been completed.
- Now that the pump has been stopped you may remove it from the system.
- Protect the inlet and outlet openings of the pump with adapted protective plugs or screws.

7.8 Trouble shooting

If the pump stops operating abruptly or has difficulties with starting operation, please undertake the following steps:

Try to liberate the micro annular gear pump:

- by turning the potentiometer knob back and forth or by connecting an analog voltage
- via the control software
- by pressing with a syringe a suitable flushing liquid (see table 21 and table 22) through the micro annular gear pump
- by changing the operating direction of the pump.

If these measures turn out to be ineffective, please contact the service staff of HNP Mikrosysteme (see chapter 15) and send the pump back to the manufacturer for inspection.

Warning

You should under no condition try to disassemble the pump by yourself. This may cause damage to the pump components and consequently annul your warranty claims.

7.9 Return of the micro annular gear pump to the manufacturer

For the return of a micro annular gear pump and components that have already been employed, please follow the instructions:

- drain any remaining rests of the delivered liquid from the pump
- flush the pump with an adapted solvent
- remove the filter elements from integrated or loosely delivered filters
- protect all openings against dust with the delivered protective plugs or screws
- return the pump in its original packing

The service personnel which carries out the repair should be informed about the condition of the already used micro annular gear pump. This is done by means of the "Declaration of media in contact with the micro annular gear pump and its components" (see chapter 16). This form may also be downloaded from the web site www.hnp-mikrosysteme.de/download.



The "Declaration of liquids in contact with the micro annular gear pump and its components" must imperatively be filled in. The nature of liquid which entered into contact with the micro annular gear pump and its components must be specified.

In case of non-compliance, the sender will be liable for any resulting injure to persons or any object damage.

8 Maintenance and service

8.1 Micro annular gear pumps

The first maintenance of the micro annular gear pumps has to take place after 4000 hours or after 6 month latest. If wear is low at the first inspection further maintenance intervals at the same operation conditions can be extended to 6000 hours or to a service interval of 12 month latest.

If there is increased wear at the first inspection the maintenance intervals have to be adapted according to the wear situation.

In case of maintenance and service please send the micro annular gear pump to your distributor or HNP Mikrosysteme directly. The address you may find on the front page of the manual or in section 15.

The micro annular gear pumps is sealed. It is prohibited to open or disassemble the pump. The warranty will expire immediately in such a case. HNP Mikrosysteme cannot give any warranty for replacing in case of damages to the pump which are related to faulty operation.

8.2 Metal bellow-type coupling

Maintenance of the standard metal bellow-type coupling is not necessary according to the enclosed manufacturer's data when assembled by HNP Mikrosysteme.

Within the maintenance intervals of the pump the screw tightening torque must be checked after 6000 hours. If at the first inspection damage at the metal bellow-type coupling is found the maintenance intervals have to be adapted according to the operational data. This check must be part of the maintenance intervals of the micro annular gear pump.

8.3 Ex-Motor

The explosion proof motor itself is maintenance free. According to the manufacturer's instruction the explosion proof motor has to be checked 1-2 times per year regarding cracks and damages. This check must be part of the maintenance intervals of the micro annular gear pump.

9 Problems and their removal

Disturbance	Cause	Solution	
1 The pump does not work.	No power supply	Check the power supply.	
2 The pump does not pump the liquid.	No liquid in the primary tank	Fill the recipient/tank with liquid.	
	Presence of air or gas in the pump	The pump cannot run dry against the system pressure. Fill in the pump at no pressure or at reduced system pressure.	
	Malfunction of the liquid supply components (such as in the delivery tube, the needle or external non-return valve)	Check the components for possible disturbances to be eliminated. Cleanse the accessories where needed.	
	Failure of the electric installation	Check the electric installation for the correct cable configuration, loose contacts, etc.	
	The pump did not receive the start signal or start conditions are not fulfilled.	Check if the start condition have been fulfilled start signals (software control, PLC, start signal) and the programs.	
3 The pump does not start to operate.	Motor disturbance: the red error LED is on.	Check the failure condition of the motor control with the Motion Manager software.	
	The pump does not take in the liquid.	The tubing on the induction side is too long or has a too small internal diameter (a too low NPSHA value).	
		The tubing or the fluid connection on the induction (suction) side are not tight. Please check the intake connection and the tubing.	
		Air bubbles in the fluid system (tubes, valves, ...)	
		If the viscosity of the liquid is too high, apply pressure on the suction side.	
		Check the pressure exerted on the primary liquid tank.	
		An external non-return valve does not open. Check the non-return valves.	
Submit the non-return valve to a higher pressure, so that the pump may fill in.			
4 The motor turns, but the pump does not operate.	No liquid in the pump	Fill the pump with liquid.	
	Air bubbles in the liquid supply system (tubing, valves, ...)	Fill the pump and the liquid supply system with liquid.	
	The non-return valve does not open.	Rinse the non-return valve.	
	Blocked delivery tubing or needle	Cleansing, flushing or exchange of the delivery tubing or dosage needle	
	The coupling between the motor and the pump is out of position.	Return the pump to the manufacturer.	
	The pump shaft is broken.	Return the pump to the manufacturer.	
5 The pump is filled with liquid, but does not pump it.	Error indicator (the red status LED on the terminal box is on and the motor control has set the error output).	Check the motor error status with the Motion Manager software (command GFS). Try to liberate the pump by making it operate for 1 s in a reverse direction with -1000 rpm. Adapt the motor current to the control. Contact the manufacturer of the pump.	
	Presence of particles in the delivered liquid or blockage of the pump.	Check the motor error status with the Motion Manager software. Try to liberate the pump by making it operate for 1 s in a reverse direction with -1000 rpm. Return the pump to the manufacturer for cleansing. Use a filter, flush the liquid delivery	

Disturbance	Cause	Solution
		system.
		Flush the pump with a syringe.
	The non-return valve does not open.	Rinse the non-return valve.
	Blockage of the delivery tubing or the needle.	Cleanse, flush or exchange the delivery tubing or the needle.
	Air bubbles in the liquid delivery system, (tubing, valves)	Fill in the pump and the delivery system with liquid.
6 Dosage volume does not correspond to the set values.	Air bubbles in the liquid delivery system, (tubing, valves ,...) and the pump	Vent the liquid delivery system and check for untight fluid connections.
	Pump shows cavitation.	Too long or too narrow intake tubing. Shorten the intake tubing or change the position of the pump.
	Polluted or too small filter	Change the filter to a new or bigger one.
	The non-return valve does not open.	Rinse the non-return valve.
7 Speed of the pump cannot be adjusted.	Defective electric installation	Check the electric installation for correct cable configuration and loose contacts.
	Defective drive control	Return the drive control to the manufacturer.
8 Liquid drops from the dosing needle.	The non-return valve does not close.	Rinse the non-return valve.
	Too high pressure on the primary liquid tank	Stop the delivery of compressed air on the primary liquid tank.
	The liquid tank is placed at a higher level than the dosing needle.	Place the liquid tank at the same or slightly lower level than the pump.
9 Liquid leaks from the fluidic seal.	The connection kit of the fluidic seal module is untight.	Check the assembly, tighten the threaded connections.
	Pressure on the induction tank of the fluidic seal liquid	Stop the delivery of compressed air on the sealing liquid tank Defective sealing - if necessary return the pump to the manufacturer.
10 The dosage volume decreases with time.	Polluted filter.	Exchange the filter.
	Deposits in the pump.	Flush the pump or return it to the manufacturer for dismantling and cleaning.
	The pump is worn after a long operating period or after use with abrasive liquids.	New definition of the calibration factor of the pump, by modifying the pump characteristics graph necessary.
11 Leakage from the pump	The sealing does not function correctly.	Return the pump to the manufacturer.
12 Leakage from the coupling assembly	Defective shaft seal	Return the pump to the manufacturer to change the shaft sealing.
13 Leakage from the fluid connections	Untight lock rings	Exchange or tighten the fluid connections, exchange the fluid connection fittings.
14 Air bubbles on the delivery side	Loose fluid connections (particularly on the induction side)	Check and tighten the fluid connections.
	The shaft seal is untight or worn.	Return the pump to the manufacturer.
15 Minimal leakage during standstill	No error, cause relative to the operating principle	Employ a non-return valve. Place the liquid tank at the same or slightly lower level than the pump
16 Excess temperature	The surface of the pump is hot.	Clean the surface of the pump, rinse the pump
	The pump operates with difficulty.	The pump should be flushed.
	Particles in the delivered liquid or deposits in the pump	The operation of the pump should immediately be stopped! Return the pump to the manufacturer for cleansing.
	Noise of beveling	The operation of the pump should immediately be stopped! Return the pump to the manufacturer for cleansing and repair.
	The motor surface or the motor interior are too hot.	High temperature indicator in the drive is on. The motor has been shut down by the thermistor. Return the pump to the

Disturbance	Cause	Solution
		manufacturer.
17 The pump is noisy	Wearout of the pump or defective components	Do not continue to operate the pump, return it to the manufacturer for maintenance.
18 Lack of connection with the RS-232 interface	The pump is not connected.	Check the power supply 24 VDC.
	The drive control does not respond.	Check the connection of the interface and the null-modem cable. Change the cable if necessary. Interrupt the voltage supply for about 10 s, connect the voltage supply again. Automatic start of the integrated drive control
19 Overcurrent	Particles in the delivered liquid	Rinse the pump.
	The pump operates with difficulty.	Dosing needle is damaged. Needle should be cleansed, flushed or exchanged. Tubing on the delivery side, dosing needle or non-return valve are blocked. Cleanse, flush or exchange the components.
	Deposits inside the pump.	Flush the pump. If necessary return the pump to the manufacturer.
20 Undervoltage	Voltage supply < 12 VDC	Check the power supply 24 VDC.
21 Overvoltage	Voltage supply > 28 VDC	Check the power supply 24 VDC. The drive control may be damaged. Return the pump to the manufacturer.

Table 26

Trouble shooting guide

If unknown faults appear or an uncertainty arises from appearing faults in the working with the pump, immediately shut down the micro annular gear pump at first!

10 Software »Motion Manager«

For the programming of the micro annular gear pump the software » Motion Manager « must be installed (see section 6.8). The connection from controller to PC with the delivered zero modem cable has to be established and the micro annular gear pump have been taken into service.

10.1 Command mode

With software »Motion Manager« commands can be entered and sent directly to the motion controller to change the settings of the controller or execute movements.

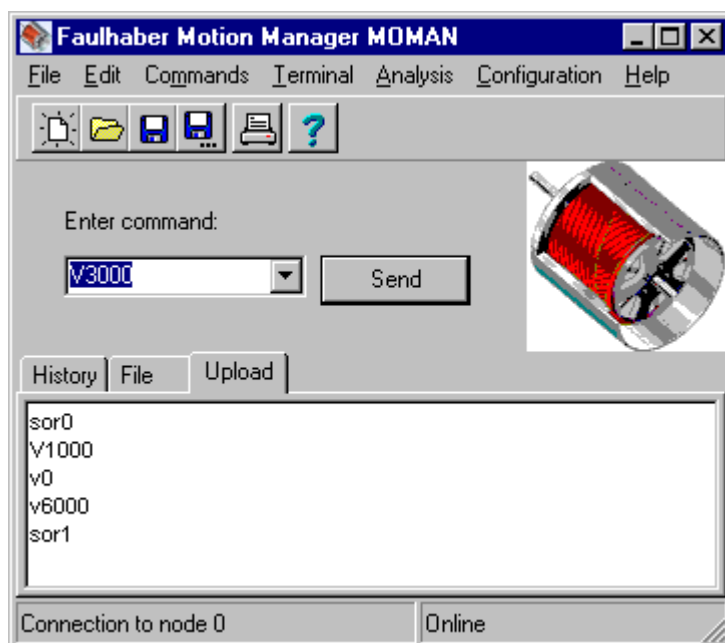

Figure 28

Program »Motion Manager« for direct control commands for the micro annular gear pump

The entry of command lines takes place in the field »Enter command:«. When the command entry is completed this must be confirmed by pressing the button »Send« to send. The commands can alternatively be written in capital or small letters. Surplus blanks are ignored by the motion controller.

Example for feeding

Command	Description
SOR0	Operation mode »RS-232«, <i>Source For Velocity</i> - set velocity with RS-232 command
V1000	Rotate with 1000 rpm (equivalent flow for mzs-2509 Ex = 1,5 ml/min, mzs-2909 Ex = 3 ml/min; mzs-4609 Ex = 12 ml/min; mzs-7209 Ex = 48 ml/min)
V0	Stop pump rotation (speed 0 rpm)
V3000	Rotate with 3000 rpm (equivalent flow for mzs-2509 Ex = 4,5 ml/min, mzs-2909 Ex = 9 ml/min; mzs-4609 Ex = 36 ml/min; mzs-7209 Ex = 144 ml/min)
SOR1	Operation mode »analogue input«, <i>Source For Velocity</i> - set velocity with potentiometer setting on the connection panel

Example for dosage

Command	Description
SOR0	Operation mode »RS-232«, <i>Source For Velocity</i> - set velocity with RS-232 command
LR10000	Load relative position at 10000 to the pump 10000 = 5 revolution (equivalent quantity mzs-2509 Ex \approx 7.5 μ l mzs-2909 Ex \approx 15 μ l; mzs-4609 Ex \approx 60 μ l, mzs-7209 Ex \approx 240 μ l) (explanation: 2000 steps = 1 revolution)
M	Start positioning pump
LR20000	Load relative position at 20000 to the pump 20000 = 10 revolution, (equivalent quantity mzs-2509 Ex \approx 15 μ l mzs-2909 Ex \approx 30 μ l; mzs-4609 Ex \approx 120 μ l mzs-7209 Ex \approx 480 μ l)
M	Start positioning pump
SOR1	Operation mode »analogue input«, <i>Source For Velocity</i> - set velocity with potentiometer setting on the connection panel

Regarding the four flank **analysis** of the encoder signal in the controller S-HD-KL the counter of the position must be set four times the amount of revolutions. To use the »Motion Manager« software please also refer to the online help function of the program.

10.2 Programming of motion controller

For dedicated applications (e.g. communication with process control, or dosage parameters according to sensor input) the motion controller S-HD-KL can be programmed with a simple program language. The program files consist of ASCII-commands. The filenames can be saved with the extension »mcl« (*motion controller language*). All motor settings can be set via the RS-232 port (e.g. maximum velocity, acceleration, relative position in position control mode, current parameter continuous and peak and the digital filter parameter for the dynamic performance). All settings and files can be stored to the onboard memory. Depending on the operation mode the motion controller therefore can run stand-alone.

The delivery volume comprises a disk with sample mcl-files which can be downloaded to the controller and stored permanently to the EEPROM.

10.3 Transfer of mcl-files to motor controller

mcl-files can be loaded over *File – Open* in the file-editor-screen.

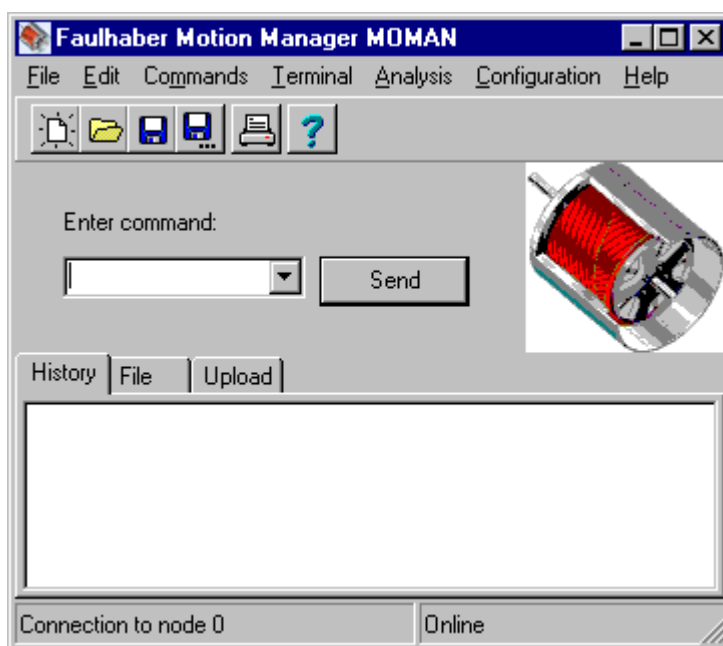

Figure 29

Menu *File – Open*

The required mcl file may be selected and loaded from the file selection window (see figure 24).

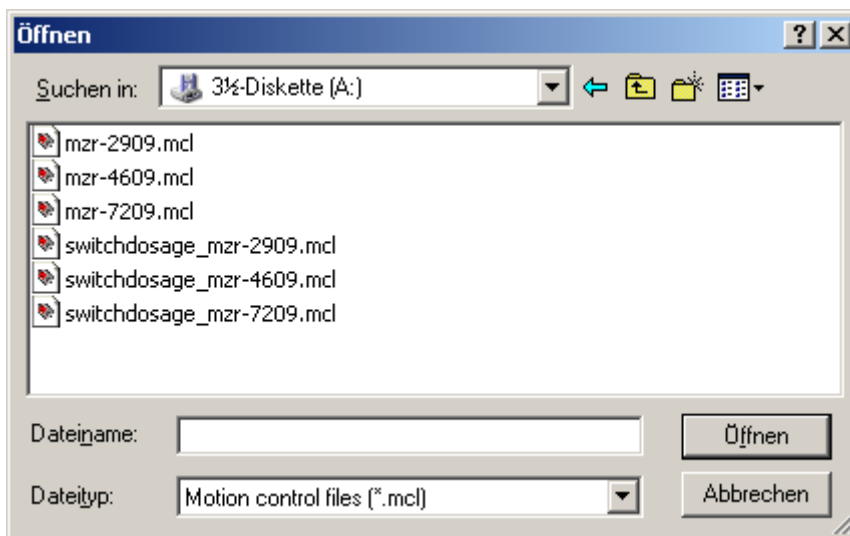

figure 30 File selection window

Open the window *Terminal – Transfer configuration files* for file transfer to the motion controller.

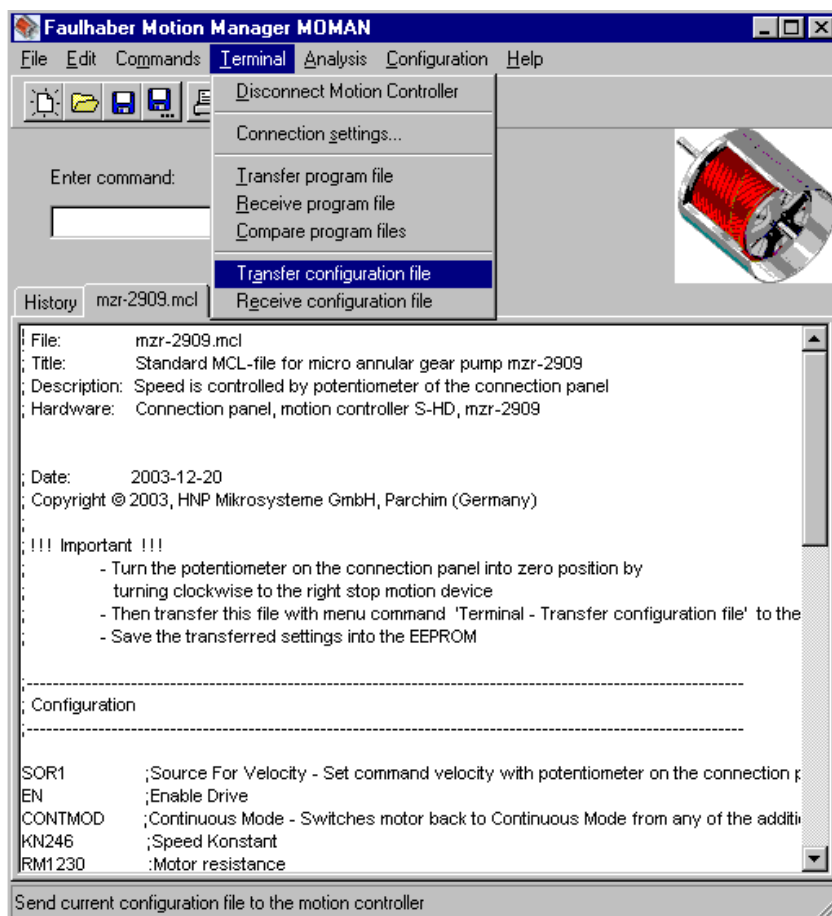

Figure 31 Transfer of mcl-file as Transfer configuration files

When a window appears with the enquiry if the mcl files should be transferred to the »Motion-Controller«, answer by clicking on the »Yes« button.

In order to save the configuration and the programmed operation files in the EEPROM, please confirm the dialogue window with »OK« (see figure 26). With this confirmation the program will be saved in the memory with a resident status and will be available for future operation.

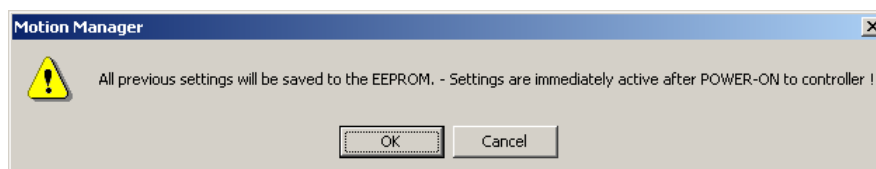

figure 32

Storage confirmation

For saving of settings of the configuration or program sequence in the onboard memory (EEPROM) answer the question »Should the EEPSAV command be carried out and the transferred settings saved?« with »Yes«. At that time the settings are written to the EEPROM. After switch on/off of the motion controller settings and program is available.

The delivery volume comprises the standard program *mzr-2509_S.mcl*, *mzr-2909_S.mcl*, *mzr-4609_S.mcl*, *mzr-7209_S.mcl* and the sample programs *switchdosage_2509_S.mcl*, *switchdosage_2909_S.mcl*, *switchdosage_4609_S.mcl* and *switchdosage_7209_S.mcl* for triggered dosage with an external switch.

The standard program *mzr-2509_S.mcl* (see Listing 1) is saved at delivery state of the micro annular gear pump mzr-2509 Ex.

Upon delivery the motion controller is configured with following parameter:

- Operation mode analogue input, Source for velocity via potentiometer (Command SOR1)
- Enable driver (Command EN)
- Continuous mode (Command CONTMOD)
- Maximum velocity 4700 U/min (Command SP4700)
- Maximum peak current 800 mA (Command LPC800)
- Maximum continuous current 600 mA (Command LCC600)
- Acceleration 550 U/s² (Command AC550)
- Fault pin as error output (Command ERROUT)
- Asynchronous answer (Command ANSW1)
- Clear program memory with no programs

```

; File:                mzr-2509_S.mcl
; Description:        Standard mcl-file for micro annular gear pump mzr-2509Ex
;                    Speed is controlled by potentiometer of the connection panel
;                    Fault as error output program
; Hardware:          Motion Controller S-HD-KL, Steuerung MCDC3006S, Schnittstelle RS-232
;
; Date:              2012-03-29
; Copyright © 2012, HNP Mikrosysteme GmbH, Parchim
;
; HNP Mikrosysteme GmbH, Juri-Gagarin-Ring 4, 19370 Parchim
; Telefon +49(0)3871/451-301, Telefax +49(0)3871/451-333
; Email info@hnp-mikrosysteme.de, http://www.hnp-mikrosysteme.de
;
;-----
; Configuration Motor
;-----

SOR1                ;Source For Velocity - Sollzahl über Potentiometer
CONTMOD             ;Continuous Mode - Normalbetrieb
KN246               ;Load Speed Constant - Drehzahlkonstante laden [rpm/V]
RM1230              ;Load Motor Resistance - Motorwiderstand laden [mOhm]
APL0                ;Position Limits - Positionslimits deaktivieren
MOTTYP8             ;Motor Type - EC-Motor 3564K024B C
POHOSEQ0            ;Power On Homing Sequence - Keine Homing-Sequenze nach dem
Einschalten
ERROUT              ;Error Output - Umschalten auf Fehlerausgangsmodus
HP7                 ;Hard Polarity - alle Eingänge steigende Flanke gültig
HB0                 ;Hard Blocking - Kein Hard-Blocking
HD0                 ;Hard Direction - Für alle Endschalter Linkslauf sperren (falls Hard-Blocking
aktiv)

```

```

HOSP100 ;Load Homing Speed - Homing-Speed auf Rechtslauf mit 100 rpm
SHA0 ;Set Home Arming - deaktivieren
SHL0 ;Set Hard Limit - deaktivieren
SHN0 ;Set Hard Notify - deaktivieren
ADR ;Analog Direction Right - Positive Spannung für Rechtsdrehung
LPC800 ;Load Peak Current Limit - Spitzenstrom [mA] laden
LCC600 ;Load Continius Current Limit - Dauerstrom [mA] laden
AC550 ;Load Command Acceleration - Beschleunigung laden [U/s²]
DEC550 ;Load Command Deceleration - Bremsverzögerung laden [U/s²]
I25 ;Load Velocity Integral Term - Drehzahlreglerintegralanteil laden
POR3 ;Load Velocity Proportional Term - Drehzahlreglerverstärkung laden
PP162 ;Load Position Proportional Term - Ladereglerverstärkung laden
PD5 ;Load Position D-Term - Lageregler D-Anteil laden
CI16 ;Load Current Intergral Term - Integralanteil für Stromregler laden
SP4700 ;Load maximum Speed - Maximaldrehzahl laden [rpm]
MVO ;Minimum Velocity - Minimaldrehzahl laden [rpm]
MAV25 ;Minimum Analog Voltage - minimale Anlaufspannung in [mV]
LL600000000 ;Load Position Range Limits - obere Grenzpositionen laden
LL-600000000 ;Load Position Range Limits - Untere Grenzpositionen laden
LPN10 ;Load Puls Number - Impulszahl vorgeben
STW1 ;Load Step Width - Schrittweite an Motor senden
STN500 ;Load Step Number - Anzahl der Schritte pro Umdrehung laden
ENCRES2000 ;Load Encoder Resolution - Encoderauflösung Motor
DEV25 ;Load Deviation - größte zulässige Drehzahlabweichung laden
DCE200 ;Delayed Current Error - verzögerter Fehlerausgang [in 1/100 Sek.]
CORRIDOR10 ;Load Corridor - Fenster um die Zielposition laden
SIN1 ;Sinus Commutation
SETPLC ;Set PLC-Inputs - Eingangsspiegel auf PLC Kompatible 24 VDC
EN ;Enable Drive - Antrieb aktivieren
V0 ;Select Velocity Mode - Drehzahl [rpm] auf 0 setzen
DIPROG ;Disable Program - Ausführung des Programmes deaktivieren
COMPATIBLE0 ;Deactivated Compatible Mode - Kompatibilität zu Vorgängermodellen
deaktivieren
SR1 ;Load Sample rate - Reglerabtastrate [1 = 100µs]
NET0 ;Set Network Mode - Netzwerkbetrieb deaktiviert
ANSW1 ;Answer Mode- asynchronen Rückmeldungen über RS232 erlauben

-----
; Programm
-----

PROGSEQ ;leeres Programm schreiben und speichern um eventuelle Programme zu
überschreiben
END

```

Listing 1

File m zr-2509 Ex.mcl

The standard program *m zr-2909_S.mcl* (see Listing 1) is saved at delivery state of the micro annular gear pump m zr-2909 Ex.

Upon delivery the motion controller is configured with following parameter:

- Operation mode analogue input, Source for velocity via potentiometer (Command SOR1)
- Enable driver (Command EN)
- Continuous mode (Command CONTMOD)
- Maximum velocity 4700 U/min (Command SP4700)
- Maximum peak current 800 mA (Command LPC800)
- Maximum continuous current 600 mA (Command LCC600)
- Acceleration 550 U/s² (Command AC550)
- Fault pin as error output (Command ERROUT)

- Asynchronous answer (Command ANSW1)
- Clear program memory with no programs

```

; File:                mZR-2909_S.mcl
; Description:         Standard mcl-file for micro annular gear pump mZR-2909Ex
;                     Speed is controlled by potentiometer of the connection panel
;                     Fault as error output program
; Hardware:           Motion Controller S-HD-KL, Steuerung MCDC3006S, Schnittstelle RS-232
;
; Date:               2012-03-29
; Copyright © 2012, HNP Mikrosysteme GmbH, Parchim
;
; HNP Mikrosysteme GmbH, Juri-Gagarin-Ring 4, 19370 Parchim
; Telefon +49(0)3871/451-301, Telefax +49(0)3871/451-333
; Email info@hnp-mikrosysteme.de, http://www.hnp-mikrosysteme.de
;
;-----
; Configuration Motor
;-----
SOR1                ;Source For Velocity - Soll Drehzahl über Potentiometer
CONTMOD             ;Continuous Mode - Normalbetrieb
KN246               ;Load Speed Constant - Drehzahlkonstante laden [rpm/V]
RM1230              ;Load Motor Resistance - Motorwiderstand laden [mOhm]
APL0                ;Position Limits - Positionslimits deaktivieren
MOTYP8             ;Motor Type - EC-Motor 3564K024B C
POHOSEQ            ;Power On Homing Sequence - Keine Homing-Sequenz nach dem
Einschalten
ERRORT              ;Error Output - Umschalten auf Fehlerausgangsmodus
HP7                 ;Hard Polarity - alle Eingänge steigende Flanke gültig
HB0                 ;Hard Blocking - Kein Hard-Blocking
HD0                 ;Hard Direction - Für alle Endschalter Linkslauf sperren (falls Hard-Blocking
aktiv)
HOSP100             ;Load Homing Speed - Homing-Speed auf Rechtslauf mit 100 rpm
SHA0                ;Set Home Arming - deaktivieren
SHL0                ;Set Hard Limit - deaktivieren
SHN0                ;Set Hard Notify - deaktivieren
ADR                 ;Analog Direction Right - Positive Spannung für Rechtsdrehung
LPC800              ;Load Peak Current Limit - Spitzenstrom [mA] laden
LCC600              ;Load Continius Current Limit - Dauerstrom [mA] laden
AC550               ;Load Command Acceleration - Beschleunigung laden [U/s²]
DEC550              ;Load Command Deceleration - Bremsverzögerung laden [U/s²]
I25                 ;Load Velocity Integral Term - Drehzahlreglerintegralanteil laden
POR3                ;Load Velocity Proportional Term - Drehzahlreglerverstärkung laden
PP162               ;Load Position Proportional Term - Ladereglerverstärkung laden
PD5                 ;Load Position D-Term - Lageregler D-Anteil laden
CI16                ;Load Current Intergral Term - Integralanteil für Stromregler laden
SP4700              ;Load maximum Speed - Maximaldrehzahl laden [rpm]
MV0                 ;Minimum Velocity - Minimaldrehzahl laden [rpm]
MAV25               ;Minimum Analog Voltage - minimale Anlaufspannung in [mV]
LL600000000         ;Load Position Range Limits - obere Grenzpositionen laden
LL-600000000        ;Load Position Range Limits - Untere Grenzpositionen laden
LPN10               ;Load Puls Number - Impulszahl vorgeben
STW1                ;Load Step Width - Schrittweite an Motor senden
STN500              ;Load Step Number - Anzahl der Schritte pro Umdrehung laden
ENCRES2000          ;Load Encoder Resolution - Encoderauflösung Motor
DEV25               ;Load Deviation - größte zulässige Drehzahlabweichung laden
DCE200              ;Delayed Current Error - verzögerter Fehlerausgang [in 1/100 Sek.]
CORRIDOR10          ;Load Corridor - Fenster um die Zielposition laden
SIN1                ;Sinus Commutation
SETPLC              ;Set PLC-Inputs - Eingangspegel auf PLC Kompatible 24 VDC
EN                  ;Enable Drive - Antrieb aktivieren
V0                  ;Select Velocity Mode - Drehzahl [rpm] auf 0 setzen
DIPROG              ;Disable Program - Ausführung des Programmes deaktivieren
COMPATIBLE0         ;Deactivated Compatible Mode - Kompatibilität zu Vorgängermodellen
deaktivieren
SR1                 ;Load Sample rate - Reglerabtastrate [1 = 100µs]
NET0                ;Set Network Mode - Netzwerkbetrieb deaktiviert
ANSW1               ;Answer Mode- asynchronen Rückmeldungen über RS232 erlauben

```

```
-----  
; Programm  
-----  
PROGSEQ  
;leeres Programm schreiben und speichern um eventuelle Programme zu  
überschreiben  
END
```

Listing 2

File mzr-2909_S.mcl

The standard program *mzr-4609_S.mcl* (see Listing 3) is saved at delivery state of the micro annular gear pump mzr-4609 Ex.

Upon delivery the motion controller is configured with following parameter:

- Operation mode Analogue input, Source for velocity via potentiometer (Command SOR1)
- Enable driver (Command EN)
- Continuous mode (Command CONTMOD)
- Maximum Velocity 4700 U/min (Command SP4700)
- Maximum peak current 900 mA (Command LPC900)
- Maximum continuous current 700 mA (Command LCC700)
- Acceleration 550 U/s² (Command AC550)
- Fault pin as error output (Command ERROUT)
- Asynchronous answer (Command ANSW1)
- Clear program memory with no programs

```

; File:                mzr-4609_S.mcl
; Description:         Standard mcl-file for micro annular gear pump mzr-4609Ex
;                     Speed is controlled by potentiometer of the connection panel
;                     Fault as error output program
; Hardware:           Motion Controller S-HD-KL, Steuerung MCDC3006S, Schnittstelle RS-232
;
; Date:               2012-03-29
; Copyright © 2012, HNP Mikrosysteme GmbH, Parchim
;
; HNP Mikrosysteme GmbH, Juri-Gagarin-Ring 4, 19370 Parchim
; Telefon +49(0)3871/451-301, Telefax +49(0)3871/451-333
; Email info@hnp-mikrosysteme.de, http://www.hnp-mikrosysteme.de
;
;-----
; Configuration Motor
;-----

SOR1                ;Source For Velocity - Soll Drehzahl über Potentiometer
CONTMOD             ;Continuous Mode - Normalbetrieb
KN246              ;Load Speed Constant - Drehzahlkonstante laden [rpm/V]
RM1230             ;Load Motor Resistance - Motorwiderstand laden [mOhm]
APL0               ;Position Limits - Positionslimits deaktivieren
MOTTYP8            ;Motor Type - EC-Motor 3564K024B C
POHOSEQ0           ;Power On Homing Sequence - Keine Homing-Sequenz nach dem
Einschalten
ERROUT             ;Error Output - Umschalten auf Fehlerausgangsmodus
HP7                ;Hard Polarity - alle Eingänge steigende Flanke gültig
HB0                ;Hard Blocking - Kein Hard-Blocking
HD0                ;Hard Direction - Für alle Endschalter Linkslauf sperren (falls Hard-Blocking
aktiv)
HOSP100            ;Load Homing Speed - Homing-Speed auf Rechtslauf mit 100 rpm
SHA0               ;Set Home Arming - deaktivieren
SHL0               ;Set Hard Limit - deaktivieren
SHN0               ;Set Hard Notify - deaktivieren
ADR                ;Analog Direction Right - Positive Spannung für Rechtsdrehung
LPC900             ;Load Peak Current Limit - Spitzenstrom [mA] laden
LCC700             ;Load Continius Current Limit - Dauerstrom [mA] laden
AC550              ;Load Command Acceleration - Beschleunigung laden [U/s²]
DEC550             ;Load Command Deceleration - Bremsverzögerung laden [U/s²]
I25                ;Load Velocity Integral Term - Drehzahlreglerintegralanteil laden
POR3               ;Load Velocity Proportional Term - Drehzahlreglerverstärkung laden
PP162              ;Load Position Proportional Term - Ladereglerverstärkung laden
PD5                ;Load Position D-Term - Lageregler D-Anteil laden
CI16               ;Load Current Intergral Term - Integralanteil für Stromregler laden
SP4700             ;Load maximum Speed - Maximaldrehzahl laden [rpm]
MV0                ;Minimum Velocity - Minimaldrehzahl laden [rpm]
MAV25              ;Minimum Analog Voltage - minimale Anlaufspannung in [mV]
LL600000000        ;Load Position Range Limits - obere Grenzpositionen laden

```

```

LL-60000000      ;Load Position Range Limits - Untere Grenzpositionen laden
LPN10            ;Load Puls Number - Impulszahl vorgeben
STW1             ;Load Step Width - Schrittweite an Motor senden
STN500          ;Load Step Number - Anzahl der Schritte pro Umdrehung laden
ENCRES2000      ;Load Encoder Resolution - Encoderauflösung Motor
DEV25           ;Load Deviation - größte zulässige Drehzahlabweichung laden
DCE200         ;Delayed Current Error - verzögerter Fehlerausgang [in 1/100 Sek.]
CORRIDOR10     ;Load Corridor - Fenster um die Zielposition laden
SIN1            ;Sinus Commutation
SETPLC          ;Set PLC-Inputs - Eingangspegel auf PLC Kompatible 24 VDC
EN             ;Enable Drive - Antrieb aktivieren
V0             ;Select Velocity Mode - Drehzahl [rpm] auf 0 setzen
DIPROG         ;Disable Program - Ausführung des Programmes deaktivieren
COMPATIBLE0    ;Deactivated Compatible Mode - Kompatibilität zu Vorgängermodellen
deaktivieren
SR1            ;Load Sample rate - Reglerabtastrate [1 = 100µs]
NET0           ;Set Network Mode - Netzwerkbetrieb deaktiviert
ANSW1         ;Answer Mode- asynchronen Rückmeldungen über RS232 erlauben

;-----
; Programm
;-----

PROGSEQ          ;leeres Programm schreiben und speichern um eventuelle Programme zu
überschreiben
END

```

Listing 3

File m zr-4609_S.mcl

The standard program *m zr-7209_S.mcl* (see Listing 4) is saved at delivery state of the micro annular gear pump m zr-7209 Ex.

Upon delivery the motion controller is configured with following parameter:

- Operation state analogue input, Source for velocity over the potentiometer (Command SOR1)
- Enable driver (Command EN)
- Continuous mode (Command CONTMOD)
- Maximum Velocity 4700 U/min (Command SP4700)
- Maximum peak current 2000 mA (Command LPC2000)
- Maximum continuous current 1800 mA (Command LCC1800)
- Acceleration 550 U/s² (Command AC550)
- Fault pin as error output (Command ERROUT)
- Asynchronous answer (Command ANSW1)
- Clear program memory with no programs

```

; File:          m zr-7209_S.mcl
; Description:   Standard mcl-file for micro annular gear pump m zr-7209Ex
;               Speed is controlled by potentiometer of the connection panel
;               Fault as error output program
; Hardware:     Motion Controller S-HD-KL, Steuerung MCDC3006S, Schnittstelle RS-232
;
; Date:         2012-03-29
; Copyright © 2012, HNP Mikrosysteme GmbH, Parchim
;
; HNP Mikrosysteme GmbH, Juri-Gagarin-Ring 4, 19370 Parchim
; Telefon +49(0)3871/451-301, Telefax +49(0)3871/451-333
; Email info@hnp-mikrosysteme.de, http://www.hnp-mikrosysteme.de
;

```

```

;-----
; Configuration Motor
;-----

SOR1           ;Source For Velocity - Solldrehzahl über Potentiometer
CONTMOD        ;Continuous Mode - Normalbetrieb
KN246         ;Load Speed Constant - Drehzahlkonstante laden [rpm/V]
RM1230        ;Load Motor Resistance - Motorwiderstand laden [mOhm]
APL0          ;Position Limits - Positionslimits deaktivieren
MOTYP8        ;Motor Type - EC-Motor 3564K024B C
POHOSEQ0      ;Power On Homing Sequence - Keine Homing-Sequenze nach dem
Einschalten
ERROUT        ;Error Output - Umschalten auf Fehlerausgangsmodus
HP7           ;Hard Polarity - alle Eingänge steigende Flanke gültig
HB0           ;Hard Blocking - Kein Hard-Blocking
HD0           ;Hard Direction - Für alle Endschalter Linkslauf sperren (falls Hard-Blocking
aktiv)
HOSP100       ;Load Homing Speed - Homing-Speed auf Rechtslauf mit 100 rpm
SHA0          ;Set Home Arming - deaktivieren
SHL0          ;Set Hard Limit - deaktivieren
SHN0          ;Set Hard Notify - deaktivieren
ADR           ;Analog Direction Right - Positive Spannung für Rechtsdrehung
LPC2000       ;Load Peak Current Limit - Spitzenstrom [mA] laden
LCC1800       ;Load Continius Current Limit - Dauerstrom [mA] laden
AC550         ;Load Command Acceleration - Beschleunigung laden [U/s²]
DEC550        ;Load Command Deceleration - Bremsverzögerung laden [U/s²]
I25           ;Load Velocity Integral Term - Drehzahlreglerintegralanteil laden
POR3          ;Load Velocity Proportional Term - Drehzahlreglerverstärkung laden
PP162         ;Load Position Proportional Term - Ladereglerverstärkung laden
PD5           ;Load Position D-Term - Lageregler D-Anteil laden
CI16          ;Load Current Intergral Term - Integralanteil für Stromregler laden
SP4700        ;Load maximum Speed - Maximaldrehzahl laden [rpm]
MV0           ;Minimum Velocity - Minimaldrehzahl laden [rpm]
MAV25         ;Minimum Analog Voltage - minimale Anlaufspannung in [mV]
LL600000000   ;Load Position Range Limits - obere Grenzpositionen laden
LL-600000000  ;Load Position Range Limits - Untere Grenzpositionen laden
LPN10         ;Load Puls Number - Impulszahl vorgeben
STW1          ;Load Step Width - Schrittweite an Motor senden
STN500        ;Load Step Number - Anzahl der Schritte pro Umdrehung laden
ENCRES2000    ;Load Encoder Resolution - Encoderauflösung Motor
DEV25         ;Load Deviation - größte zulässige Drehzahlabweichung laden
DCE200        ;Delayed Current Error - verzögerter Fehlerausgang [in 1/100 Sek.]
CORRIDOR10    ;Load Corridor - Fenster um die Zielposition laden
SIN1          ;Sinus Commutation
SETPLC        ;Set PLC-Inputs - Eingangspegel auf PLC Kompatible 24 VDC
EN            ;Enable Drive - Antrieb aktivieren
V0           ;Select Velocity Mode - Drehzahl [rpm] auf 0 setzen
DIPROG        ;Disable Program - Ausführung des Programmes deaktivieren
COMPATIBLE0   ;Deactivated Compatible Mode - Kompatibilität zu Vorgängermodellen
deaktivieren
SR1           ;Load Sample rate - Reglerabtastrate [1 = 100µs]
NET0          ;Set Network Mode - Netzwerkbetrieb deaktiviert
ANSW1         ;Answer Mode- asynchronen Rückmeldungen über RS232 erlauben

;-----
; Programm
;-----

PROGSEQ       ;leeres Programm schreiben und speichern um eventuelle Programme zu
überschreiben
END

```

Listing 4

File mzr-7209_S.mcl

The file *switchdosage_m zr-2509_S.mcl* (see Listing 5) is an example for dosage with one micro annular gear pump m zr-2509 Ex.

Trigger start of the dosage with switch located between clamp »Fault« and »GND« of the connection board. A closing switch or a floating switch of a PLC can be used as trigger.

In the program the motion controller is programmed with following setting parameters:

- Load relative Position of the pump 10 revolution (Command LR20000) (20000 = 10 revolution => m zr-2509 Ex \approx 15 μ l)
- Start of dosage with switch (Command REFIN)

```

; File:          switchdosage_2509_e3_S.mcl
; Description:   Dosage triggered with switch for m zr-2509 Ex
;               Start dosage with switch on digital input 3
;               Fault as error output programmed
; Hardware:     Motion Controller S-HD-KL with switch, Controller MCDC3006S, Interface RS-232
;
; Date:         2012-03-29
; Copyright © 2012, HNP Mikrosysteme GmbH, Parchim
;
; HNP Mikrosysteme GmbH, Juri-Gagarin-Ring 4, 19370 Parchim
; Telefon +49(0)3871/451-301, Telefax +49(0)3871/451-333
; Email: info@hnp-mikrosysteme.de, http://www.hnp-mikrosysteme.de
;
; !!! Important !!!
;               - Turn the potentiometer on the connection panel into zero position by
;               turning clockwise to the right stop motion device
;               - Then transfer this file with menu command 'Terminal - Transfer configuration file' to the
;               pump
;               - Save the transferred settings into the EEPROM
;
;-----
; Program sequence
;-----
PROGSEQ          ;Program start

A1              ;Label 1 (program start)
HP4             ;Rising edge active and logic level to High for input No. 3
A2              ;Label 2
JPT2            ;Cycle 2 Low-Pegel on Input 3
HP0             ;Falling edge active and logic level to Low for input No. 3
A3              ;Label 3
JPT3            ;Cycle 3 bis High-Pegel on Input 3

HO              ;Set the actual position to 0
LR20000         ;Load relative target position (2000 = 1 rev.) <----- Please edit the target
position value !
NP              ;Notify Position (wait after "M" until target position is reached)
M              ;Move to target position

JMP1            ;Jump to the beginning

END

;-----
; Configuration
;-----

SOR0            ;Source For Velocity - Solldrehzahl über Schnittstelle RS-232
CONTMOD         ;Continuous Mode - Normalbetrieb
KN246           ;Load Speed Constant - Drehzahlkonstante laden [rpm/V]
RM1230          ;Load Motor Resistance - Motorwiderstand laden [mOhm]
APL0            ;Position Limits - Positionslimits deaktivieren
MOTTYP8        ;Motor Type - EC-Motor 3564K024B C

```

POHOSEQ0	;Power On Homing Sequence - Keine Homing-Sequenze nach dem Einschalten
ERROUT	;Error Output - Umschalten auf Fehlerausgangsmodus
HP7	;Hard Polarity - alle Eingänge steigende Flanke gültig
HB0	;Hard Blocking - Kein Hard-Blocking
HD0	;Hard Direction - Für alle Endschalter Linkslauf sperren (falls Hard-Blocking aktiv)
HOSP100	;Load Homing Speed - Homing-Speed auf Rechtslauf mit 100 rpm
SHA0	;Set Home Arming - deaktivieren
SHL0	;Set Hard Limit - deaktivieren
SHN0	;Set Hard Notify - deaktivieren
ADR	;Analog Direction Right - Positive Spannung für Rechtsdrehung
LPC800	;Load Peak Current Limit - Spitzenstrom [mA] laden
LCC600	;Load Continius Current Limit - Dauerstrom [mA] laden
AC550	;Load Command Acceleration - Beschleunigung laden [U/s ²]
DEC550	;Load Command Deceleration - Bremsverzögerung laden [U/s ²]
I25	;Load Velocity Integral Term - Drehzahlreglerintegralanteil laden
POR2	;Load Velocity Proportional Term - Drehzahlreglerverstärkung laden
PP3	;Load Position Proportional Term - Ladereglervverstärkung laden
PD20	;Load Position D-Term - Lageregler D-Anteil laden
CI16	;Load Current Intergral Term - Integralanteil für Stromregler laden
SP3000	;Load maximum Speed - Maximaldrehzahl laden [rpm]
MV0	;Minimum Velocity - Minimaldrehzahl laden [rpm]
MAV25	;Minimum Analog Voltage - minimale Anlaufspannung in [mV]
LL600000000	;Load Position Range Limits - obere Grenzpositionen laden
LL-600000000	;Load Position Range Limits - Untere Grenzpositionen laden
LPN10	;Load Puls Number - Impulszahl vorgeben
STW1	;Load Step Width - Schrittweite an Motor senden
STN500	;Load Step Number - Anzahl der Schritte pro Umdrehung laden
ENCRES2000	;Load Encoder Resolution - Encoderauflösung Motor
DEV25	;Load Deviation - größte zulässige Drehzahlabweichung laden
DCE200	;Delayed Current Error - verzögerter Fehlerausgang [in 1/100 Sek.]
CORRIDOR100	;Load Corridor - Fenster um die Zielposition laden
SIN1	;Sinus Commutation
SETPLC	;Set PLC-Inputs - Eingangsspiegel auf PLC Kompatible 24 VDC
EN	;Enable Drive - Antrieb aktivieren
COMPATIBLE0	;Deactivated Compatible Mode - Kompatibilität zu Vorgängermodellen deaktivieren
SR1	;Load Sample rate - Reglerabtastrate [1 = 100µs]
NET0	;Set Network Mode - Netzwerkbetrieb deaktiviert
ANSW1	;Answer Mode- asynchronen Rückmeldungen über RS232 erlauben
LR0	;Load relative position - Anzahl Umdrehungen 1000=1 U laden
M	;Start positioning - Positionierung starten
ENPROG	;Enable Program - Ausführung des Programmes aktivieren

Listing 5

File *switchdosage_mzr-2509_S.mcl*

The file *switchdosage_mzr-2909_S.mcl* (see Listing 5) is an example for dosage with one micro annular gear pump mzr-2909 Ex.

Trigger start of the dosage with switch located between clamp »Fault« and »GND« of the connection board. A closing switch or a floating switch of a PLC can be used as trigger.

In the program the motion controller is programmed with following setting parameters:

- Load relative Position of the pump 10 revolution (Command LR20000)
(20000 = 10 revolution => mzr-2909 Ex ≈ 30 µl)
- Start of dosage with switch (Command REFIN)

```

; File:          switchdosage_2909_e3_S.mcl
; Description:   Dosage triggered with switch for m zr-2909 Ex
;               Start dosage with switch on digital input 3
;               Fault as error output programmed
; Hardware:     Motion Controller S-HD-KL with switch, Controller MCDC3006S, Interface RS-232
;
; Date:         2012-03-29
; Copyright © 2012, HNP Mikrosysteme GmbH, Parchim
;
; HNP Mikrosysteme GmbH, Juri-Gagarin-Ring 4, 19370 Parchim
; Telefon +49(0)3871/451-301, Telefax +49(0)3871/451-333
; Email: info@hnp-mikrosysteme.de, http://www.hnp-mikrosysteme.de
;
; !!! Important !!!
;               - Turn the potentiometer on the connection panel into zero position by
;               turning clockwise to the right stop motion device
;               - Then transfer this file with menu command 'Terminal - Transfer configuration file' to the
; pump
;               - Save the transferred settings into the EEPROM
;
;-----
; Program sequence
;-----
PROGSEQ          ;Program start

A1              ;Label 1 (program start)
HP4             ;Rising edge active and logic level to High for input No. 3
A2              ;Label 2
JPT2           ;Cycle 2 Low-Pegel on Input 3
HP0             ;Falling edge active and logic level to Low for input No. 3
A3              ;Label 3
JPT3           ;Cycle 3 bis High-Pegel on Input 3

HO              ;Set the actual position to 0
LR20000        ;Load relative target position (2000 = 1 rev.) <----- Please edit the target
position value !
NP             ;Notify Position (wait after "M" until target position is reached)
M              ;Move to target position

JMP1           ;Jump to the beginning

END

;-----
; Configuration
;-----

SOR0           ;Source For Velocity - Solldrehzahl über Schnittstelle RS-232
CONTMOD        ;Continuous Mode - Normalbetrieb
KN246         ;Load Speed Constant - Drehzahlkonstante laden [rpm/V]
RM1230        ;Load Motor Resistance - Motorwiderstand laden [mOhm]
APL0          ;Position Limits - Positionslimits deaktivieren
MOTYP8        ;Motor Type - EC-Motor 3564K024B C
POHOSEQ0      ;Power On Homing Sequence - Keine Homing-Sequenze nach dem
Einschalten
ERROUT        ;Error Output - Umschalten auf Fehlerausgangsmodus
HP7           ;Hard Polarity - alle Eingänge steigende Flanke gültig
HB0           ;Hard Blocking - Kein Hard-Blocking
HD0           ;Hard Direction - Für alle Endschalter Linkslauf sperren (falls Hard-Blocking
aktiv)
HOSP100       ;Load Homing Speed - Homing-Speed auf Rechtslauf mit 100 rpm
SHA0         ;Set Home Arming - deaktivieren
SHL0         ;Set Hard Limit - deaktivieren
SHN0         ;Set Hard Notify - deaktivieren
ADR           ;Analog Direction Right - Positive Spannung für Rechtsdrehung
LPC800       ;Load Peak Current Limit - Spitzenstrom [mA] laden
LCC600       ;Load Continius Current Limit - Dauerstrom [mA] laden
AC550        ;Load Command Acceleration - Beschleunigung laden [U/s²]
DEC550       ;Load Command Deceleration - Bremsverzögerung laden [U/s²]
I25          ;Load Velocity Integral Term - Drehzahlreglerintegralanteil laden
POR2         ;Load Velocity Proportional Term - Drehzahlreglerverstärkung laden
PP3          ;Load Position Proportional Term - Ladereglerverstärkung laden

```

PD20	;Load Position D-Term - Lageregler D-Anteil laden
CI16	;Load Current Intergral Term - Integralanteil für Stromregler laden
SP3000	;Load maximum Speed - Maximaldrehzahl laden [rpm]
MV0	;Minimum Velocity - Minimaldrehzahl laden [rpm]
MAV25	;Minimum Analog Voltage - minimale Anlaufspannung in [mV]
LL600000000	;Load Position Range Limits - obere Grenzpositionen laden
LL-600000000	;Load Position Range Limits - Untere Grenzpositionen laden
LPN10	;Load Puls Number - Impulszahl vorgeben
STW1	;Load Step Width - Schrittweite an Motor senden
STN500	;Load Step Number - Anzahl der Schritte pro Umdrehung laden
ENCRES2000	;Load Encoder Resolution - Encoderauflösung Motor
DEV25	;Load Deviation - größte zulässige Drehzahlabweichung laden
DCE200	;Delayed Current Error - verzögerter Fehlerausgang [in 1/100 Sek.]
CORRIDOR100	;Load Corridor - Fenster um die Zielposition laden
SIN1	;Sinus Commutation
SETPLC	;Set PLC-Inputs - Eingangsspiegel auf PLC Kompatible 24 VDC
EN	;Enable Drive - Antrieb aktivieren
COMPATIBLE0	;Deactivated Compatible Mode - Kompatibilität zu Vorgängermodellen
deaktivieren	
SR1	;Load Sample rate - Reglerabtastrate [1 = 100µs]
NET0	;Set Network Mode - Netzwerkbetrieb deaktiviert
ANSW1	;Answer Mode- asynchronen Rückmeldungen über RS232 erlauben
LR0	;Load relative position - Anzahl Umdrehungen 1000=1 U laden
M	;Start positioning - Positionierung starten
ENPROG	;Enable Program - Ausführung des Programmes aktivieren

Listing 6

File *switchdosage_m zr-2909 Ex.mcl*

The file *switchdosage_m zr-4609_S.mcl* (see Listing 7) is an example for dosage with one micro annular gear pump m zr-4609 Ex.

Trigger start of the dosage with switch located between clamp »Fault« and »GND« of the connection board. A closing switch or a floating switch of a PLC can be used as trigger.

In the program the motion controller is programmed with following setting parameters:

- Load relative Position of the pump 10 revolution (Command LR20000) (20000 = 10 revolution m zr-4609 Ex \approx 120 μ l)
- Start of the dosage over the switch (Command REFIN)

```

; File:          switchdosage_4609_e3_S.mcl
; Description:   Dosage triggered with switch for m zr-4609 Ex
;               Start dosage with switch on digital input 3
;               Fault as error output programmed
; Hardware:     Motion Controller S-HD-KL with switch, Controller MCDC3006S, Interface RS-232
;
; Date:         2012-03-29
; Copyright © 2012, HNP Mikrosysteme GmbH, Parchim
;
; HNP Mikrosysteme GmbH, Juri-Gagarin-Ring 4, 19370 Parchim
; Telefon +49(0)3871/451-301, Telefax +49(0)3871/451-333
; Email: info@hnp-mikrosysteme.de, http://www.hnp-mikrosysteme.de
;
; !!! Important !!!
;               - Turn the potentiometer on the connection panel into zero position by
;               turning clockwise to the right stop motion device
;               - Then transfer this file with menu command 'Terminal - Transfer configuration file' to the
; pump
;               - Save the transferred settings into the EEPROM
;
;-----
; Program sequence
;-----
PROGSEQ          ;Program start

A1              ;Label 1 (program start)
HP4             ;Rising edge active and logic level to High for input No. 3
A2              ;Label 2
JPT2            ;Cycle 2 Low-Pegel on Input 3
HP0             ;Falling edge active and logic level to Low for input No. 3
A3              ;Label 3
JPT3            ;Cycle 3 bis High-Pegel on Input 3

HO              ;Set the actual position to 0
LR20000         ;Load relative target position (2000 = 1 rev.) <----- Please edit the target
position value !
NP              ;Notify Position (wait after "M" until target position is reached)
M              ;Move to target position

JMP1            ;Jump to the beginning

END

;-----
; Configuration
;-----

SOR0            ;Source For Velocity - Solldrehzahl über Schnittstelle RS-232
CONTMOD         ;Continuous Mode - Normalbetrieb
KN246           ;Load Speed Constant - Drehzahlkonstante laden [rpm/V]
RM1230         ;Load Motor Resistance - Motorwiderstand laden [mOhm]
APL0            ;Position Limits - Positionslimits deaktivieren

```

MOTYP8	;Motor Type - EC-Motor 3564K024B C
POHOSEQ0	;Power On Homing Sequence - Keine Homing-Sequenze nach dem Einschalten
ERROUT	;Error Output - Umschalten auf Fehlerausgangsmodus
HP7	;Hard Polarity - alle Eingänge steigende Flanke gültig
HB0	;Hard Blocking - Kein Hard-Blocking
HD0	;Hard Direction - Für alle Endschalter Linkslauf sperren (falls Hard-Blocking aktiv)
HOSP100	;Load Homing Speed - Homing-Speed auf Rechtslauf mit 100 rpm
SHA0	;Set Home Arming - deaktivieren
SHL0	;Set Hard Limit - deaktivieren
SHN0	;Set Hard Notify - deaktivieren
ADR	;Analog Direction Right - Positive Spannung für Rechtsdrehung
LPC900	;Load Peak Current Limit - Spitzenstrom [mA] laden
LCC700	;Load Continius Current Limit - Dauerstrom [mA] laden
AC550	;Load Command Acceleration - Beschleunigung laden [U/s ²]
DEC550	;Load Command Deceleration - Bremsverzögerung laden [U/s ²]
I25	;Load Velocity Integral Term - Drehzahlreglerintegralanteil laden
POR2	;Load Velocity Proportional Term - Drehzahlreglerverstärkung laden
PP3	;Load Position Proportional Term - Ladereglerverstärkung laden
PD20	;Load Position D-Term - Lageregler D-Anteil laden
CI16	;Load Current Intergral Term - Integralanteil für Stromregler laden
SP3000	;Load maximum Speed - Maximaldrehzahl laden [rpm]
MV0	;Minimum Velocity - Minimaldrehzahl laden [rpm]
MAV25	;Minimum Analog Voltage - minimale Anlaufspannung in [mV]
LL600000000	;Load Position Range Limits - obere Grenzpositionen laden
LL-600000000	;Load Position Range Limits - Untere Grenzpositionen laden
LPN10	;Load Puls Number - Impulszahl vorgeben
STW1	;Load Step Width - Schrittweite an Motor senden
STN500	;Load Step Number - Anzahl der Schritte pro Umdrehung laden
ENCRES2000	;Load Encoder Resolution - Encoderauflösung Motor
DEV25	;Load Deviation - größte zulässige Drehzahlabweichung laden
DCE200	;Delayed Current Error - verzögerter Fehlerausgang [in 1/100 Sek.]
CORRIDOR100	;Load Corridor - Fenster um die Zielposition laden
SIN1	;Sinus Commutation
SETPLC	;Set PLC-Inputs - Eingangspegel auf PLC Kompatible 24 VDC
EN	;Enable Drive - Antrieb aktivieren
COMPATIBLE0	;Deactivated Compatible Mode - Kompatibilität zu Vorgängermodellen deaktivieren
SR1	;Load Sample rate - Reglerabtastrate [1 = 100µs]
NET0	;Set Network Mode - Netzwerkbetrieb deaktiviert
ANSW1	;Answer Mode- asynchronen Rückmeldungen über RS232 erlauben
LR0	;Load relative position - Anzahl Umdrehungen 1000=1 U laden
M	;Start positioning - Positionierung starten
ENPROG	;Enable Program - Ausführung des Programmes aktivieren

Listing 7

File *switchdosage_m zr-4609_S.mcl*

The file *switchdosage_m zr-7209_S.mcl* (see Listing 8) is an example for dosage with one micro annular gear pump m zr-7209 Ex.

Trigger start of the dosage with switch located between clamp »Fault« and »GND« of the connection board. A closing switch or a floating switch of a PLC can be used as trigger.

In the program the motion controller is programmed with following setting parameters:

- Load relative Position of the pump 10 revolution (Command LR20000)
(20000 = 10 revolution m zr-7209 Ex ≈ 480 µl)
- Start of the dosage over the switch (Command REFIN)

```

; File:          switchdosage_7209_e3_S.mcl
; Description:   Dosage triggered with switch for m zr-7209 Ex
;               Start dosage with switch on digital input 3
;               Fault as error output programmed
; Hardware:     Motion Controller S-HD-KL with switch, Controller MCDC3006S, Interface RS-232
;
; Date:         2012-03-29
; Copyright © 2012, HNP Mikrosysteme GmbH, Parchim
;
; HNP Mikrosysteme GmbH, Juri-Gagarin-Ring 4, 19370 Parchim
; Telefon +49(0)3871/451-301, Telefax +49(0)3871/451-333
; Email: info@hnp-mikrosysteme.de, http://www.hnp-mikrosysteme.de
;
; !!! Important !!!
;               - Turn the potentiometer on the connection panel into zero position by
;               turning clockwise to the right stop motion device
;               - Then transfer this file with menu command 'Terminal - Transfer configuration file' to the
pump
;               - Save the transferred settings into the EEPROM
;
;-----
; Program sequence
;-----
PROGSEQ          ;Program start

A1              ;Label 1 (program start)
HP4             ;Rising edge active and logic level to High for input No. 3
A2              ;Label 2
JPT2            ;Cycle 2 Low-Pegel on Input 3
HP0             ;Falling edge active and logic level to Low for input No. 3
A3              ;Label 3
JPT3            ;Cycle 3 bis High-Pegel on Input 3

HO              ;Set the actual position to 0
LR20000        ;Load relative target position (2000 = 1 rev.) <----- Please edit the target
position value !
NP              ;Notify Position (wait after "M" until target position is reached)
M              ;Move to target position

JMP1            ;Jump to the beginning

END

;-----
; Configuration
;-----

SOR0            ;Source For Velocity - Solldrehzahl über Schnittstelle RS-232
CONTMOD        ;Continuous Mode - Normalbetrieb
KN246          ;Load Speed Constant - Drehzahlkonstante laden [rpm/V]
RM1230         ;Load Motor Resistance - Motorwiderstand laden [mOhm]
APL0           ;Position Limits - Positionslimits deaktivieren
MOTYP8        ;Motor Type - EC-Motor 3564K024B C
POHOSEQ0      ;Power On Homing Sequence - Keine Homing-Sequenze nach dem
Einschalten
ERROUT        ;Error Output - Umschalten auf Fehlerausgangsmodus
HP7           ;Hard Polarity - alle Eingänge steigende Flanke gültig
HB0           ;Hard Blocking - Kein Hard-Blocking
HD0           ;Hard Direction - Für alle Endschalter Linkslauf sperren (falls Hard-Blocking
aktiv)
HOSP100       ;Load Homing Speed - Homing-Speed auf Rechtslauf mit 100 rpm
SHA0          ;Set Home Arming - deaktivieren
SHL0          ;Set Hard Limit - deaktivieren
SHN0          ;Set Hard Notify - deaktivieren
ADR           ;Analog Direction Right - Positive Spannung für Rechtsdrehung
LPC2000       ;Load Peak Current Limit - Spitzenstrom [mA] laden
LCC1800       ;Load Continius Current Limit - Dauerstrom [mA] laden
AC550         ;Load Command Acceleration - Beschleunigung laden [U/s²]
DEC550        ;Load Command Deceleration - Bremsverzögerung laden [U/s²]
I25           ;Load Velocity Integral Term - Drehzahlreglerintegralanteil laden
POR2          ;Load Velocity Proportional Term - Drehzahlreglerverstärkung laden
PP3           ;Load Position Proportional Term - Ladereglerverstärkung laden

```

PD20	;Load Position D-Term - Lageregler D-Anteil laden
CI16	;Load Current Intergral Term - Integralanteil für Stromregler laden
SP3000	;Load maximum Speed - Maximaldrehzahl laden [rpm]
MV0	;Minimum Velocity - Minimaldrehzahl laden [rpm]
MAV25	;Minimum Analog Voltage - minimale Anlaufspannung in [mV]
LL600000000	;Load Position Range Limits - obere Grenzpositionen laden
LL-600000000	;Load Position Range Limits - Untere Grenzpositionen laden
LPN10	;Load Puls Number - Impulszahl vorgeben
STW1	;Load Step Width - Schrittweite an Motor senden
STN500	;Load Step Number - Anzahl der Schritte pro Umdrehung laden
ENCRES2000	;Load Encoder Resolution - Encoderauflösung Motor
DEV25	;Load Deviation - größte zulässige Drehzahlabweichung laden
DCE200	;Delayed Current Error - verzögerter Fehlerausgang [in 1/100 Sek.]
CORRIDOR100	;Load Corridor - Fenster um die Zielposition laden
SIN1	;Sinus Commutation
SETPLC	;Set PLC-Inputs - Eingangsspiegel auf PLC Kompatible 24 VDC
EN	;Enable Drive - Antrieb aktivieren
COMPATIBLE0	;Deactivated Compatible Mode - Kompatibilität zu Vorgängermodellen
deaktivieren	
SR1	;Load Sample rate - Reglerabtastrate [1 = 100µs]
NET0	;Set Network Mode - Netzwerkbetrieb deaktiviert
ANSW1	;Answer Mode- asynchronen Rückmeldungen über RS232 erlauben
LR0	;Load relative position - Anzahl Umdrehungen 1000=1 U laden
M	;Start positioning - Positionierung starten
ENPROG	;Enable Program - Ausführung des Programmes aktivieren

Listing 8

File *switchdosage_mzr-7209_S.mcl*

11 Accessories

The accessories available from HNP Mikrosysteme for micro fluidic systems comprise pipes, tubes, filters, fluidic connectors and pressure control valves, offering perfect match to your m zr-pump. Your distributor or HNP Mikrosysteme will be pleased to help choosing the right accessories.

12 Non-warranty

HNP Mikrosysteme is not responsible for any damage resulting from non-compliance of this manual for micro annular gear pumps.

The user is responsible for compliance of legal formalities pursuant to law in force, regulations under federal law, regulations in force, etc. This is true especially for feeding of aggressive, poisonous, corrosive etc. liquids and electromagnetic compatibility.

13 EC Directive

A Directive or EC Directive is a legal instrument of the European Community addressing at the member states and forcing them to implement specific regulations or targets. Leastwise, micro annular gear pumps are covered, by the scope of application of the following Directives: The following directives are of importance for the user of the described micro annular gear pumps:

Low-Voltage Directive (2014/35/EC)

The Low-Voltage Directive is not relevant for micro annular gear pumps described in this manual, because the supply voltage is limited to a maximum of 30 VDC.

Machinery Directive (2006/42/EC)

A micro annular gear pump is a machine and is consequently covered by this Directive. However, it may be a part of a machine or installation.

EMC Directive (2014/30/EU)

The Directive on Electromagnetic Compatibility (EMC) applies to all electronic and electrical devices, installations and systems. Consequently, the Motion Controller of the micro annular gear pump is covered by the EMC Directive.

RoHS Directive (2002/95/EC)

To our knowledge our products delivered to you do not contain substances or applications in concentrations that are forbidden by this directive. No substances contain our products delivered to you after our current knowledge in concentrations or application, the placing on the market in products according to the valid requirements forbade to the Directive.

WEEE Directive (2002/96/EC)



Disposal of micro annular gear pumps has to be environmentally sound. All materials and liquids have to be recycled in accordance with the relevant regulations. Electrical parts can not be disposed of as household waste. They have to be delivered to designated collection points.

REACH regulation (EC) No. 1907/2006

HNP Mikrosysteme is not a manufacturer or importer of chemical substances subjected to registration, but in terms of regulation, a downstream user. As downstream user, we conduct the necessary communication with our suppliers to ensure future deliveries of all components necessary to us. We will notify you of all relevant, changes in our products, their availability and the quality of parts/products delivered by us within our business and coordinate the appropriate action in individual cases with you. Previous inspection did not show any limitation in the supply of material from our upstream suppliers.

13.1 Electromagnetic Compatibility (EMC)

Electromagnetic compatibility is defined as the ability of a electric or electronic device to function satisfactorily as intended in its electromagnetic environment without introducing intolerable electromagnetic disturbances in that environment.

1.1.1 EMC Directive and Standards

Comformity was proven by proof of compliance with the following harmonized standards by the company Dr. Fritz Faulhaber:

- EN 61000-6-4 (10/01): Generic standards – Emission standard for industrial environments
- EN 61000-6-2 (10/01): Generic standards – Immunity for industrial environments

These standards prescribe certain standardised tests for the emitted-interference and interference-immunity tests. The following tests are required due to the connections on the controller:

Generic Standard on Emitted Interference:	Description
EN 55011 (05/98)+A1(08/99)+A2(09/02):	Radio disturbance characteristics
Generic Standard on Interference Immunity	
EN 61000-4-2 (05/95)+A1(4/98)+A2(02/01):	Electrostatic discharge immunity test
EN 61000-4-3 (04/02)+A1(10/02):	Radiated, radio-frequency, electromagnetic field immunity test
EN 61000-4-4 (09/04):	Electrical fast transient/burst immunity test
EN 61000-4-5 (03/95)+A1(02/01)	Surge immunity test
EN 61000-4-6 (07/96)+A1(02/01):	Immunity to conducted disturbances, induced by radio-frequency fields
EN 61000-4-8 (09/93)+A1(02/01):	Power frequency magnetic field immunity test

Table 2

Standards Summary

All tests were conducted successfully.

1.1.2 Information on use as intended

For micro annular gear pumps, note the following:
Requirement for the intended operation is the operation according to the technical data and the manual.

Restrictions

If the micro annular gear pumps are used at home, in business or in commerce or in small businesses, appropriate measures must be taken to ensure that emitted interferences are below the permitted limit values!

14 Declarations of conformity

Pump	Declaration of EC-Conformity (following Directive 2006/42/EC) for micro annular gear pump m zr-2509 Ex, m zr-2909 Ex, m zr-4609 Ex, m zr-7209 Ex
	Declaration of EC-Conformity (following EMC Directive 2014/308/EC) for micro annular gear pump m zr-2509 Ex, m zr-2909 Ex, m zr-4609 Ex, m zr-7209 Ex, m zr-2509X2 Ex, m zr-2909X2 Ex, m zr-4609X2 Ex, m zr-7209x2 Ex
	EC declaration / attestation of conformity (following directive 2014/34/EU) for micro annular gear pump m zr-2509 Ex, m zr-2509X2 Ex
	EC declaration / attestation of conformity (following directive 2014/34/EU) for micro annular gear pump m zr-2909 Ex, m zr-2909X2 Ex
	EC declaration / attestation of conformity (following directive 2014/34/EU) for micro annular gear pump m zr-4609 Ex, m zr-4609X2 Ex
	EC declaration / attestation of conformity (following directive 2014/34/EU) for micro annular gear pump m zr-7209 Ex, , m zr-7209X2 Ex
Coupling	EC declaration / attestation of conformity (after directive 94/9/EC)
Ex-motor	EC declaration / attestation of conformity
Thermal element :	EC declaration / attestation of conformity (after directive 94/9/EC)

table 27

Overview declarations of conformity and manufacturer's declaration

Special certification copies referring to the serial number of your Ex-motor can be obtained by the manufacturer HNP Mikrosysteme!

Declaration of EC-Conformity (following Machinery Directive 2006/42/EC)

We hereby declare that the following micro annular gear pumps of the high performance series:

**mzr-2509 Ex, mzr-2909 Ex, mzr-4609 Ex, mzr-7209 Ex,
mzr-2509X2 Ex, mzr-2909X2 Ex, mzr-4609X2 Ex, mzr-7209X2 Ex**

are intended for installation into another machinery/plant and that start of operation is forbidden until it is identified that the machinery/plant into which these micro annular gear pumps shall be installed corresponds to the regulations of the EC guidelines regarding safety and health requirements.

We confirm the conformity of the product described above to the following standards in terms of applied directives

- Directive 2006/42/EC (Community legislation on machinery)

Applied standards are particularly

DIN EN 809	DIN EN 60204-1	DIN EN ISO 13857
DIN EN ISO 12100 part 1		DIN EN 953
DIN EN ISO 12100 part 2		UVV

This statement does not warrant any characteristics in terms of product liability. Please note the safety instructions in the manual.

Mr. Lutz Nowotka, HNP Mikrosysteme GmbH, Bleicherufer 25, D-19053 Schwerin is authorised to compile the technical file according to Annex VII A.

Date: 12. August 2016

Signature manufacturer:

Dr. Thomas Weisener
CEO

Declaration of EC-Conformity (following EMC Directive 2014/30/EU)

We hereby declare that the following micro annular gear pumps of the high performance series:

**mzr-2509 Ex, mzr-2909 Ex, mzr-4609 Ex, mzr-7209 Ex,
mzr-2509X2 Ex, mzr-2909X2 Ex, mzr-4609X2 Ex, mzr-7209X2 Ex**

are intended for installation into another machinery/plant and that start of operation is forbidden till it is identified that the machinery/plant into which these micro annular gear pumps shall be installed corresponds to the regulations of the EC guidelines regarding safety and health requirements.

We confirm the conformity of the product described above to the following standards in terms of applied directives

– EMC Directive (2004/108/EC)

Applied standards are particularly

EN 61000-6-4 (10/01): Generic standards – Emission standard for industrial environments

EN 61000-6-2 (10/01): Generic standards – Immunity for industrial environments

This statement does not warrant any characteristics in terms of product liability. Please note the safety instructions in the manual.

Date: 12. August 2016

Signature manufacturer:

Dr. Thomas Weisener
CEO

EC declaration / attestation of conformity (following directive 2014/34/EU)

As per the EC directive 2014/34/EU, dated 26 February 2014 and the legislation arising from its implementation, we declares that the explosion protected product, described in the operation and safety instructions of the micro annular gear pump

mzr-2509 Ex, mzr-2509X2 Ex

is a device in the sense of Article 1, (3) a) of Directive 2014/34/EU, and complies with the essential safety and health requirements as per Appendix II of Directive 94/9/EEC and the following harmonized directives:

- DIN EN 13463-1
- DIN EN 13463-5

The specified pump type falls into the explosion protection design classification „c “.An ignition hazard assessment is available. The pump carries the identification:

CE  II 2G c IIC T5 X

The technical documentation, in compliance with Article 13, (1) b) ii) of the directive 2014/34/EU, in combination with Appendix VIII Number 2, has been deposited with the following named body

DEKRA EXAM GmbH
Dinnendahlstraße 9
D - 44809 Bochum, Germany

Date: 12. August 2016

Signature manufacturer:

Dr. Thomas Weisener
CEO

EC declaration / attestation of conformity (following directive 2014/34/EU)

As per the EC directive 2014/34/EU, dated 26 February 2014 and the legislation arising from its implementation, we declares that the explosion protected product, described in the operation and safety instructions of the micro annular gear pump

mzr-2909 Ex, mzr-2909X2 Ex

is a device in the sense of Article 1, (3) a) of Directive 2014/34/EU, and complies with the essential safety and health requirements as per Appendix II of Directive 94/9/EEC and the following harmonized directives:

- DIN EN 13463-1
- DIN EN 13463-5

The specified pump type falls into the explosion protection design classification „c “.An ignition hazard assessment is available. The pump carries the identification:

CE  II 2G c IIC T5 X

The technical documentation, in compliance with Article 13, (1) b) ii) of the directive 2014/34/EU, in combination with Appendix VIII Number 2, has been deposited with the following named body

DEKRA EXAM GmbH
Dinnendahlstraße 9
D - 44809 Bochum, Germany

Date: 12. August 2016

Signature manufacturer:

Dr. Thomas Weisener
CEO

EC declaration / attestation of conformity (following directive 2014/34/EU)

As per the EC directive 2014/34/EU, dated 26 February 2014 and the legislation arising from its implementation, we declares that the explosion protected product, described in the operation and safety instructions of the micro annular gear pump

mzr-4609 Ex, mzr-4609X2 Ex

is a device in the sense of Article 1, (3) a) of Directive 2014/34/EU, and complies with the essential safety and health requirements as per Appendix II of Directive 94/9/EEC and the following harmonized directives:

- DIN EN 13463-1
- DIN EN 13463-5

The specified pump type falls into the explosion protection design classification „c “.An ignition hazard assessment is available. The pump carries the identification:

CE  II 2G c IIC T5 X

The technical documentation, in compliance with Article 13, (1) b) ii) of the directive 2014/34/EU, in combination with Appendix VIII Number 2, has been deposited with the following named body

DEKRA EXAM GmbH
Dinnendahlstraße 9
D - 44809 Bochum, Germany

Date: 12. August 2016

Signature manufacturer:

Dr. Thomas Weisener
CEO

EC declaration / attestation of conformity (following directive 2014/34/EU)

As per the EC directive 2014/34/EU, dated 26 February 2014 and the legislation arising from its implementation, we declares that the explosion protected product, described in the operation and safety instructions of the micro annular gear pump

mzr-7209 Ex, mzr-7209X2 Ex

is a device in the sense of Article 1, (3) a) of Directive 2014/34/EU, and complies with the essential safety and health requirements as per Appendix II of Directive 94/9/EEC and the following harmonized directives:

- DIN EN 13463-1
- DIN EN 13463-5

The specified pump type falls into the explosion protection design classification „c “.An ignition hazard assessment is available. The pump carries the identification:

CE  II 2G c IIC T4 X

The technical documentation, in compliance with Article 13, (1) b) ii) of the directive 2014/34/EU, in combination with Appendix VIII Number 2, has been deposited with the following named body

DEKRA EXAM GmbH
Dinnendahlstraße 9
D - 44809 Bochum, Germany

Date: 12. August 2016

Signature manufacturer:

Dr. Thomas Weisener
CEO

Certificate

Devices for intended use in potentially explosive areas, guideline **94/9/EG - ATEX 95**

Reference no. of the technical documentation: **2003/003RW**

Device: **Metal-Bellow Coupling**
model MK/BK; Serien 0,5 bis 100 und 015 bis 10000

Manufacturer: **R+W Antriebselemente GmbH**

Address: **Alexander – Wiegand – Strasse 8**
D- 63911 Klingenberg am Main

R+W Antriebselemente GmbH herewith certifies, that this device meets the basic safety and health requirements for the design and construction of the device for its intended use in potentially explosive areas specified in appendix II of the guideline 94/9/EG.

The evaluation of the ignition source according to EN 13 463 part 1 and respective documentation **Tech.File.Ref. 2003/003RW** will be available in confidence at:

Physikalisch – Technische – Bundesanstalt PTB
Braunschweig
Bundesallee 100
D- 38116 Braunschweig

The basic safety and health requirements are met if EN 1127-1:1997, EN 13 463-1: 2002, prEN 13 463-2: 2003 and prEN 13 463-5: 2001 are complied with.

The identification of the torque limiter made of steel or stainless steel of the a.m. series includes the following details.

II 2 G D
EEx II c 40°C

R+W Antriebselemente GmbH
Alexander – Wiegand – Strasse 8
63911 Klingenberg am Main
Tel.: 09372/9864-0 Fax.: -20

Klingenberg, 17.04.03

Andreas Rimpel
Technical Director

R+W Antriebselemente
GmbH
Alexander-Wiegand-Straße 8
63911 KLINGENBERG
Tel. (09372) 9864-0 · Fax 9864-20
Internet: <http://www.rw-antriebselemente.de>

Figure 33

EC declaration / attestation of conformity for the coupling after directive 94/9/EEC (ATEX 95)

Erklärung der EG-Konformität Declaration of EC-Conformity Attestation de conformité CE		
Wir erklären in alleiniger Verantwortung, dass der	We declare that it is our sole responsibility that	Nous attestons sous notre seule responsabilité
EX MOTOR EXR...		
auf den sich diese Erklärung bezieht, den Bestimmungen der folgenden Richtlinie entspricht	to which this declaration relates is in accordance with the provision of the following directives	se referant à cette attestation correspondent aux dispositions des directives suivantes
	94/9/EC 2004/108 EG 2006/42 EG	
und mit folgenden Normen übereinstimmt.	and is in conformity with the following standards.	et sont conformes aux normes.
EN60079-0: 2009 EN 50081-1 EN60079-1: 2007	EN 61000-6-2: 2005 EN 61000-4-2(12.09)	EN 50204 (02.96) EN 55022, KL.B(08.08)
Kennzeichnung:	Marking:	Marquage:
 II 2 G Exd II C T5 Gb EXR...		
2006/42/EG Das bezeichnete Produkt ist zum Einbau in eine andere Maschine bestimmt. Die Inbetriebnahme ist solange untersagt, bis die Konformität des Endproduktes mit der Richtlinie 89/392/EWG festgestellt ist. Diese Erklärung ist keine Zusage von Eigenschaften im Sinne der Produkthaftung. Die Sicherheitshinweise der Produktdokumentation sind zu beachten.	2006/42/EG The indicated product is intended for installation into a machine. Operation is prohibited until the final product is in accordance with the 89/392/EWG regulation. This statement does not ensure any characteristics regarding Product liability. Safety instructions stated in the product description have to be respected.	2006/42/EG Le produit indiqué est prévu pour être intégré dans une machine. La mise en service n'est autorisée que lorsque la directive 89/392/EWG a été vérifiée. Cetto déclaration ne constitue pas une assurance des propriétés au sens de la responsabilité produit. Les consignes de sécurité rappelées dans la documentation du produit doivent être respectées.

ZANICA, 09.02.12

EDELWEISS ACTUATORS S.R.L.
Via Padergnone 21
24050 Zanica
Italia

Figure 34

EC declaration / attestation of conformity for the Ex-motor EXR

THERMOCOAX

from vision to reality



Item	Indicative content based on Annex X of Directive 94/09/EC
Title	EC STATEMENT OF CONFORMITY
Reference	SE900R018 rev. 2 2004-09-30
Manufacturer address	THERMOCOAX - Planquivon- Athis de l'ORNE - BP 26 - F61438 FLERS CEDEX - France
Authorized representative in EU	THERMOCOAX SAS
Manufacturer declaration	We, THERMOCOAX SAS declares that the following equipment :
	Temperature sensor Type 1 : THERMOCOUPLE Model TCD EEx ia Bearing the following markings : THERMOCOAX CE 0081  II 1 GD EEx ia II C T6-IP6X T80°C LCIE 03 ATEX 6102X
Declaration of compliance	Is designed and manufactured in compliance with the following applicable Directives.
to Applicable Directives	
First applicable Directive	- ATEX Directive 94/09/EC.
Individual declaration of compliance	Compliance has been obtained by application of the following standards :
Obtained through	EN 50014 (1997 + amendments 1 and 2) EN 50020 (2002) EN 50284 (1999) EN 50281-1-1 (1998) + amendment 1
Proof of compliance	For which an EC-Type Certificate LCIE 03 ATEX 6102 X and a Notification LCIE 03 ATEX Q 8061 according to Annexe IV have been obtained.
Under first Directive because included in the ATEX directive But not checked by the Notified Body	This product complies to electrical safety requirements, as they are expressed in the Low Voltage Directive 73/23/EEC (modified by Directive 93/68/EEC) and has been constructed in accordance to the following standards: EN 61515
Notified Bodies involved	The Notified Body responsible for monitoring the ATEX Directive is LCIE - B.P 8.- F92266 - Fontenay-aux Roses. Its Identification number is : 0081
Manufacturer's own warning	Subject to use for the purpose for which it was designed and/or installed in accordance with relevant standards and with the manufacturer's recommendations
Final declaration	We, the undersigned, hereby declare that the product(s) specified above conforms to the listed Directive(s) and standard(s)
Signatory : shall be legally responsible	 Mr Capron General Manager

figure 35

Manufacturer declaration thermocouple sensor

15 Contact persons

Development and application assistance , service and accessories

Mr. Sven Reimann
Phone +49| (0) 385|52190-349

Service and maintenance

Mr. Steffen Edler
Phone +49| (0) 385|52190-307

Drive and control technology

Mr. Lutz Nowotka
Phone +49| (0) 385|52190-346

16 Legal information

Marks

mzr® is a registered German trademark of HNP Mikrosysteme GmbH.

MoDoS® is a registered German trademark of HNP Mikrosysteme GmbH.

µ-Clamp® is a registered German trademark of HNP Mikrosysteme GmbH.

HNPM® is a registered German trademark of HNP Mikrosysteme GmbH.

Teflon® is a registered trademark of DuPont.

Viton® is a registered trademark of DuPont Dow Elastomers.

Kalrez® Spectrum™ is a registered trademark of DuPont.

PEEK™ is a registered trademark of Victrex plc.

HASTELLOY® is a registered trademark of Haynes International, Inc.

Aflas® is a registered trademark of ASAHI Glass Ltd.

Microsoft®, Windows® are registered trademarks of Microsoft Corporation in the USA and in the other countries.

Cavro® is a registered trademark of Tecan Systems, Inc.

Other product names or descriptions not mentioned above are possibly registered trademarks of related companies.

Patents

Micro annular gear pumps (and housings) are protected by assigned patents: EP 1115979 B1, US 6,520,757 B1, EP 852674 B1, US 6,179,596 B1, EP 1354135, US 7,698,818 B2. Patents pending DE 10 2011 001 041.6, PCT/IB2011/055108, EP 11 81 3388.3, US 13/884,088, CN 2011 8006 5051.7, HK 13 11 2934.9, DE 10 2011 051 486.4, PCT/EP2012/061514, EP 12 728264.8, US 9,404,492 B2, CN 2012 8003 8326.2. In the US, Europe and China additional patents are pending.

17 Safety information for the return of already employed micro annular gear pumps and components

17.1 General information

The operator carries the responsibility for health and safety of his/her employees. The responsibility extends also to employees not belonging to the company that have a direct contact with the micro annular gear pump and its components during repair or maintenance works. The nature of media (liquids) coming into contact with the micro annular gear pump and its components must be specified in the corresponding declaration form.

17.2 Declaration of liquids in contact with the micro annular gear pump

The staff performing the repair or maintenance works must be informed about the condition of the micro annular gear pump before starting any work on the device. The »Declaration of media in contact with the micro annular gear pump« should be filled in for this purpose.

The declaration should be sent directly to the supplier or to the company designated by the supplier. A second copy of the declaration must be attached to the shipment documents.

17.3 Shipment

The following instructions should be observed for the shipment of the micro annular gear pump.

- drain any remaining liquid from the pump
- flush the pump with an adapted flushing liquid
- remove the filter elements from the integrated or loosely delivered filters
- all the openings should be air-tight plugged
- return the pump in the original packing

18 Declaration of media in contact with the micro annular gear pump and its components

Type of the device

Pump type/serial number/article:

Operating hours/running time:

Bill of delivery-number and delivery date:

Reason of the return:

.....
.....

Contact with media (liquids)

The micro annular gear pump has entered into contact with:

.....

and has been cleansed with:

.....

The safety specification of the liquid has been attached (Yes / No):
or is available on the following web site: www.....

If a pump which had contact with dangerous substances could not be properly cleansed prior to the shipment, we reserve the right to entrust a specialized company with the cleansing of the device. The return of the pump in the original packing is purposive. This measure is necessary in order to protect the employees and the delivery staff.

Nature of the delivered liquid:

- | | | |
|---|--|--|
| <input type="checkbox"/> explosive | <input type="checkbox"/> oxidizing | <input type="checkbox"/> susceptible to moisture |
| <input type="checkbox"/> toxic (toxic byproducts) | <input type="checkbox"/> radioactive | <input type="checkbox"/> pH-value: |
| <input type="checkbox"/> carcinogenic | <input type="checkbox"/> microbiological | <input type="checkbox"/> other: |
| <input type="checkbox"/> caustic | <input type="checkbox"/> corrosive | |

Declaration

I/we certify herewith that the stated information is exhaustive and correct. The micro annular gear pump and corresponding liquid supply components are shipped in conformity with the applicable regulations.

Company/Institute:

Street: Zip code, location:

Telephone: Fax:

Contact person (in printed characters):

Date: Company stamp:

Obligatory signature:

19 Appendix

- Layouts
- Technical description servo drives

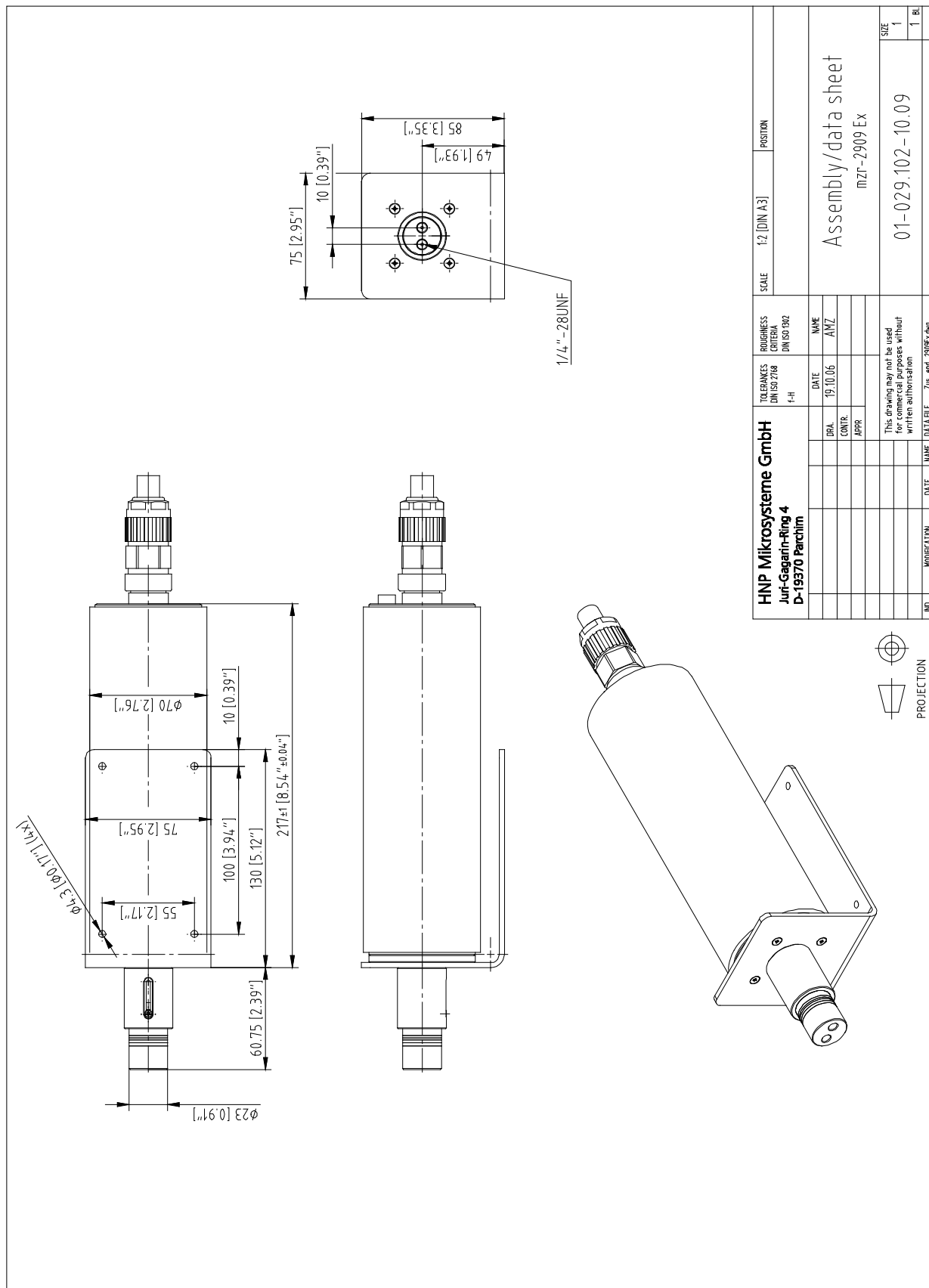

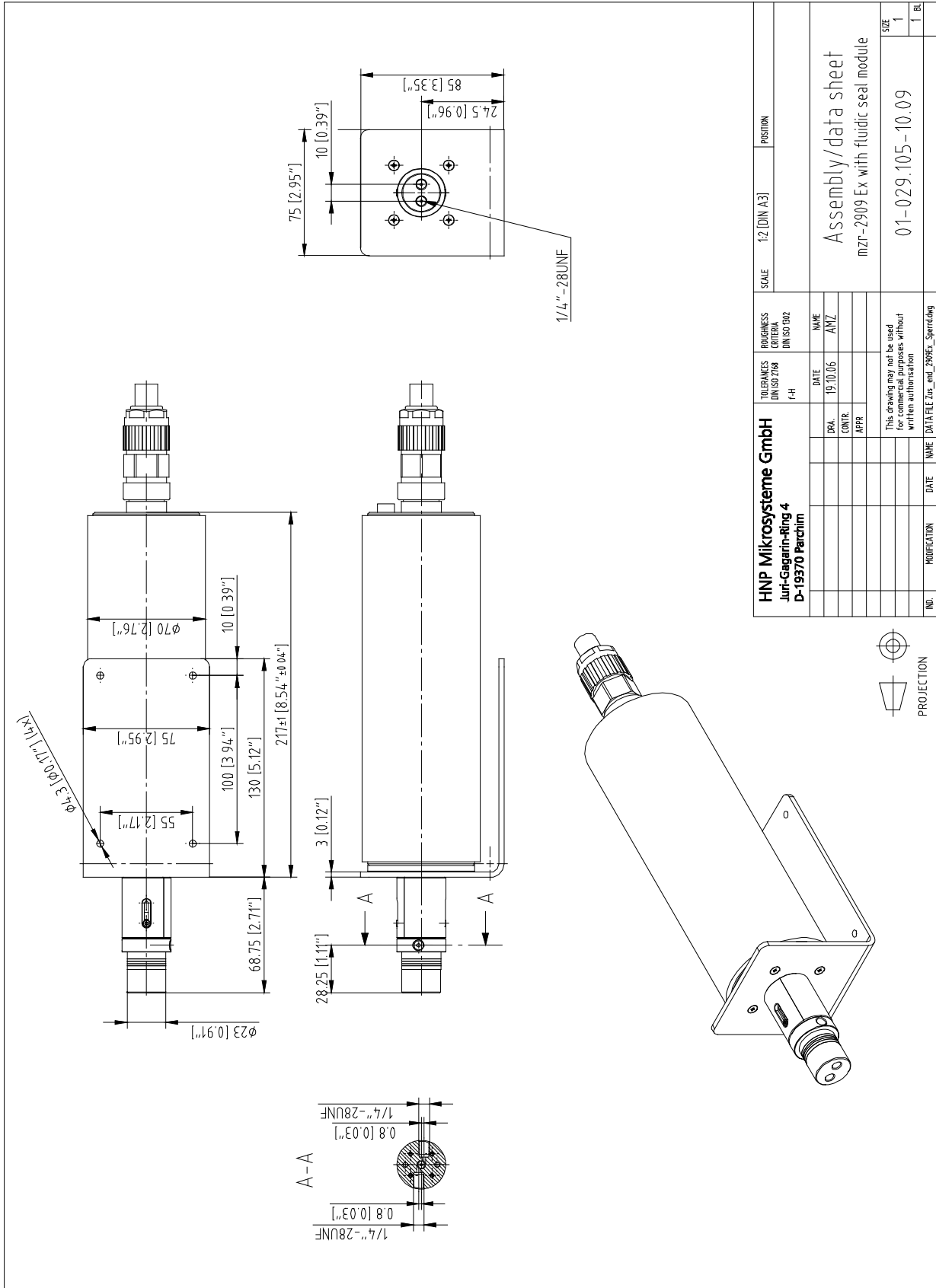

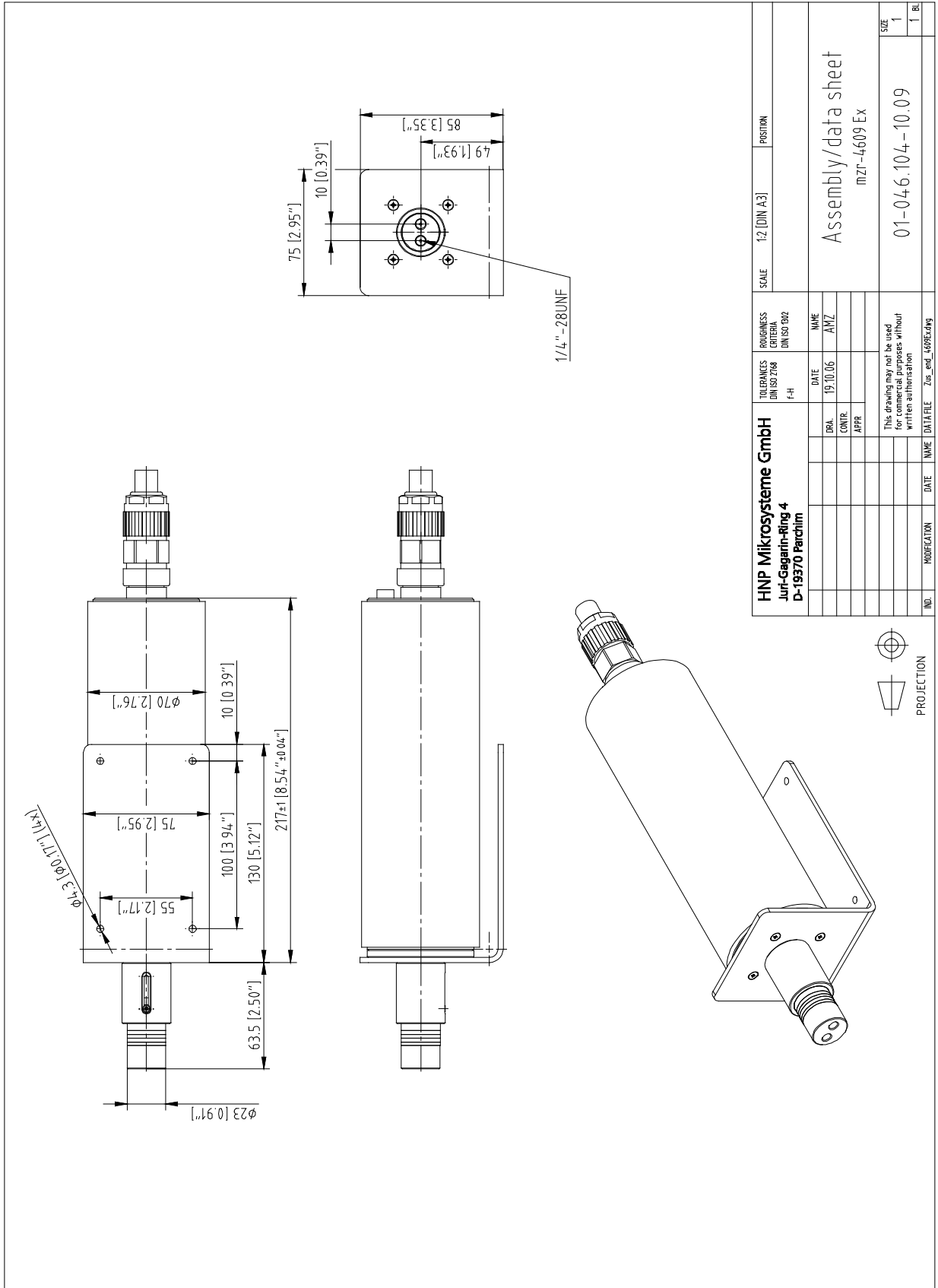

HNP Mikrosysteme GmbH		SCALE	1:2 [DIN A3]	POSITION	
Jurf-Gagarin-Ring 4		REFERENCES	PROJEKTS	Assembly/data sheet	
D-19370 Parchim		DIN ISO 2768	EXTERNAL	mZR-4609 Ex	
DRA.	DATE	F-H	DIN ISO 1802		
CONTR.	19.10.06		NAME		
APPR.			AMZ		
IND.	MODIFICATION	DATE	This drawing may not be used for commercial purposes without written authorisation		
			DATA FILE	Zus_end_4609Ex.dwg	SEE
				01-046.104-10.09	1
					1 BL

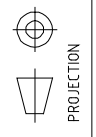

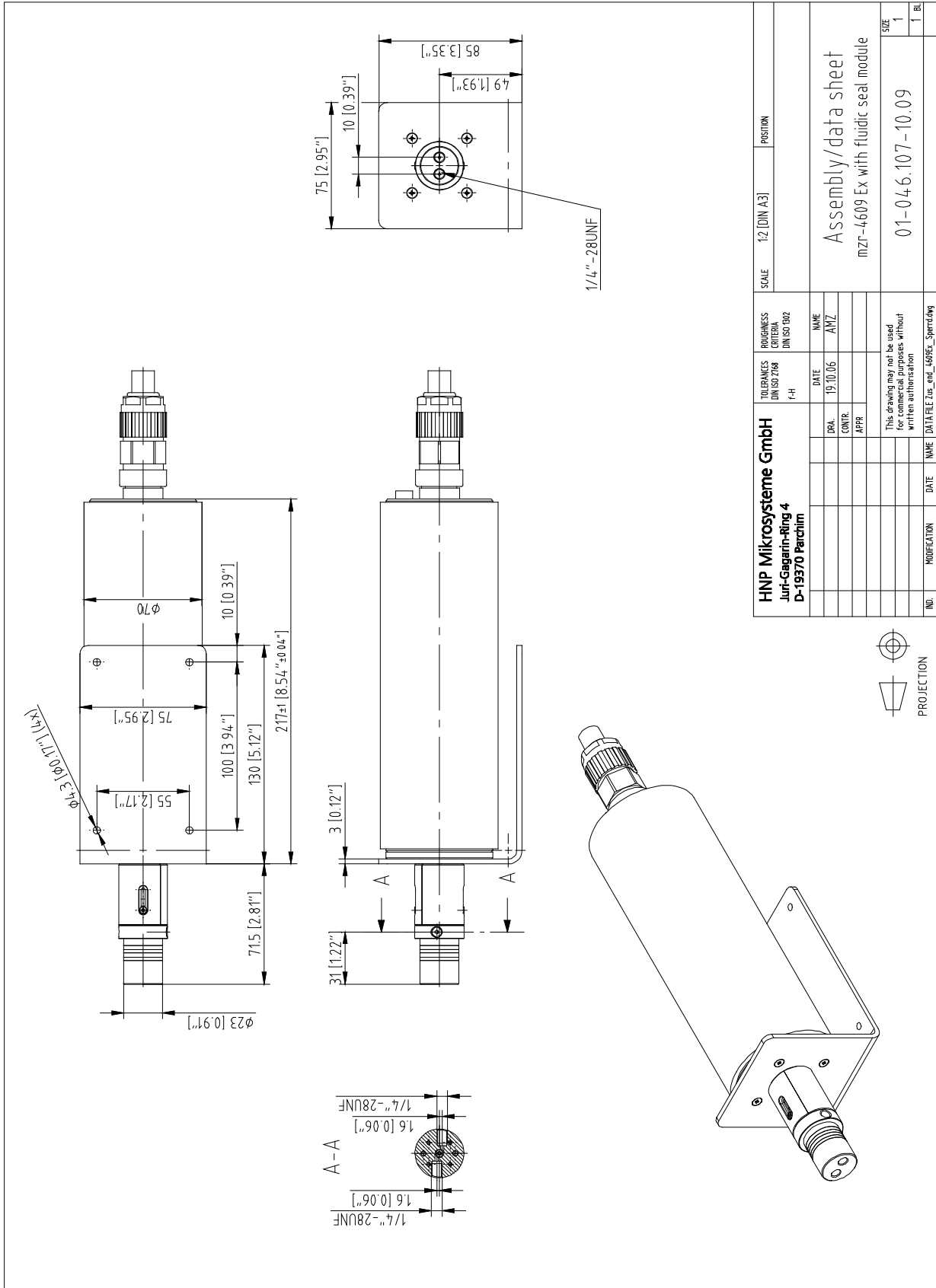

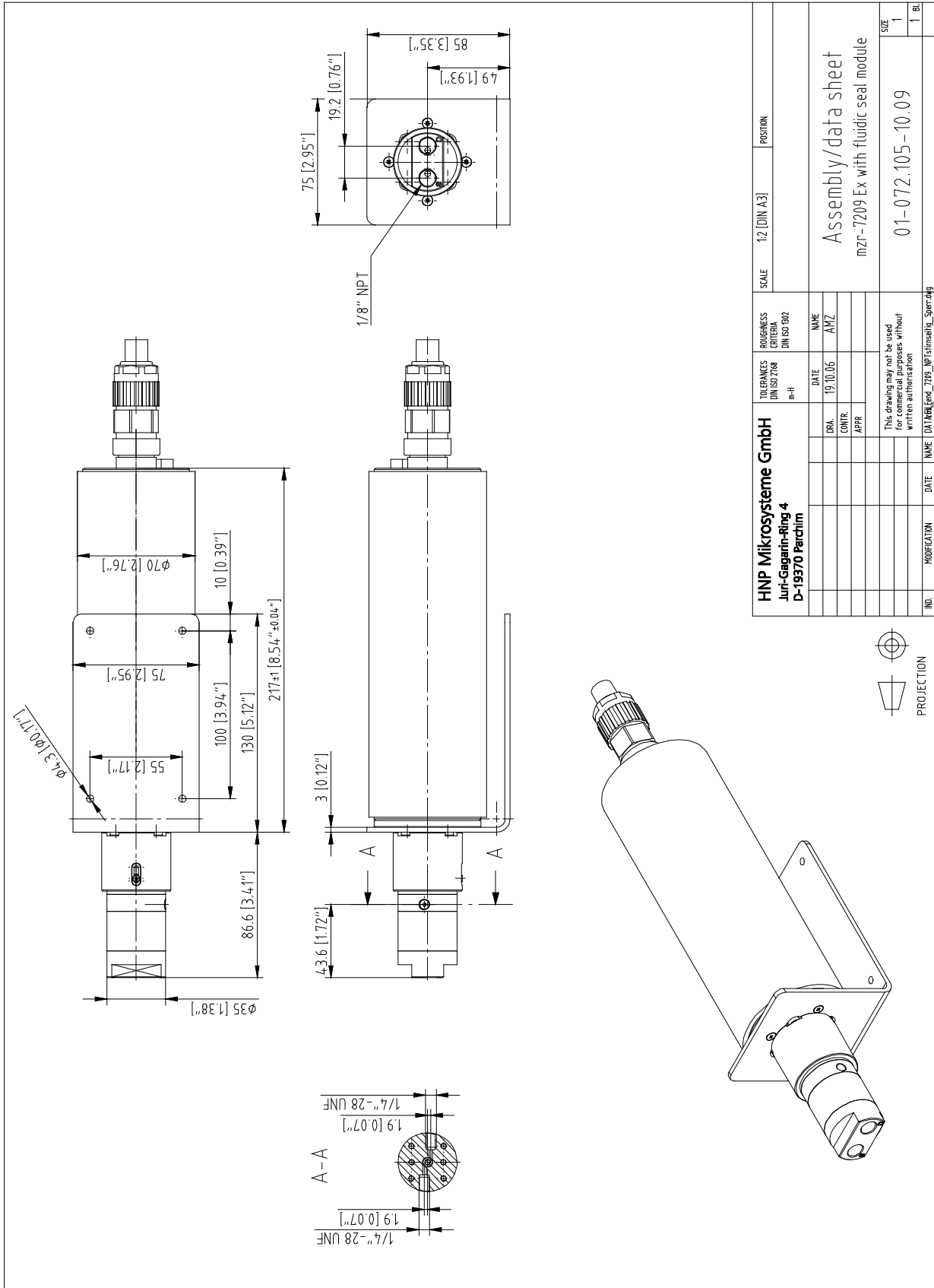

HNP Mikrosysteme GmbH Jurist-Gagarin-Ring 4 D-195370 Parchim		TOOLERANCES DIN ISO 2768 m-H	ROUGHNESS CRITERIA DIN ISO 1902	SCALE 1:2 [DIN A3]	POSITION
DATE 19.10.06	NAME AMZ	Assembly/data sheet mZR-7209 Ex with fluidic seal module			
CONTR.	APPR.				
This drawing may not be used for commercial purposes without written authorisation		SIZE 1 1 Bl.			
INC.	MODIFICATION	DATE	NAME	01-072.105-10.09	

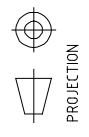

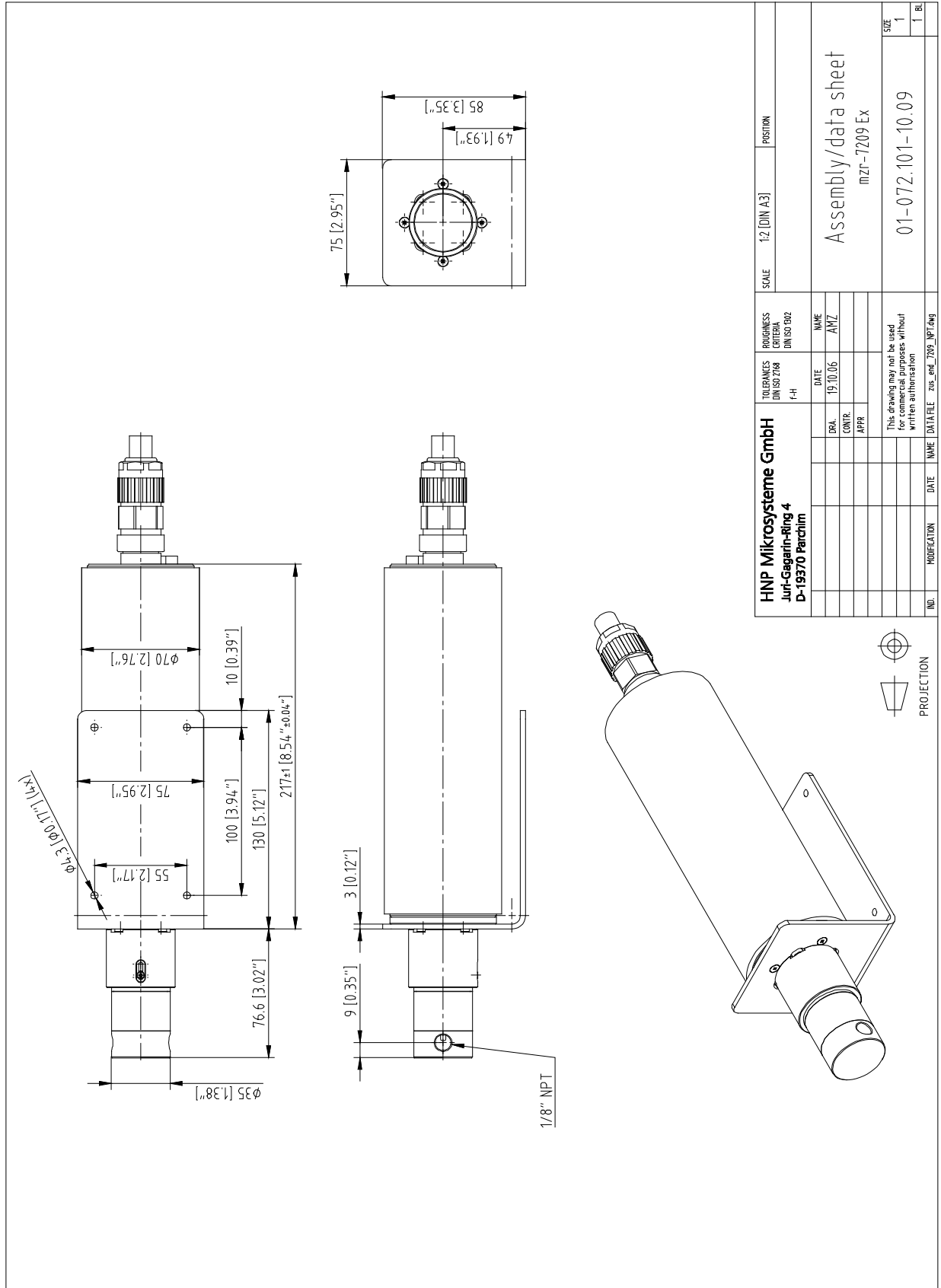

HNP Mikrosysteme GmbH Jurt-Gagarin-Ring 4 D-19370 Parchim		REFERENCES DIN ISO 2768 F-H	PROGRESS EXTERNAL DIN ISO 1902	SCALE 1:2 [DIN A3]	POSITION
DRA.	DATE	NAME	Assembly/data sheet mZR-7209 Ex		
CONTR.	19.10.06	AMZ			
APPR.					
IND.	MODIFICATION	DATE	NAME	DATA FILE sus_end_7209_NPT.dwg	
				01-072.101-10.09	
				SEE	
				1	
				1	
				BL	

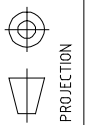

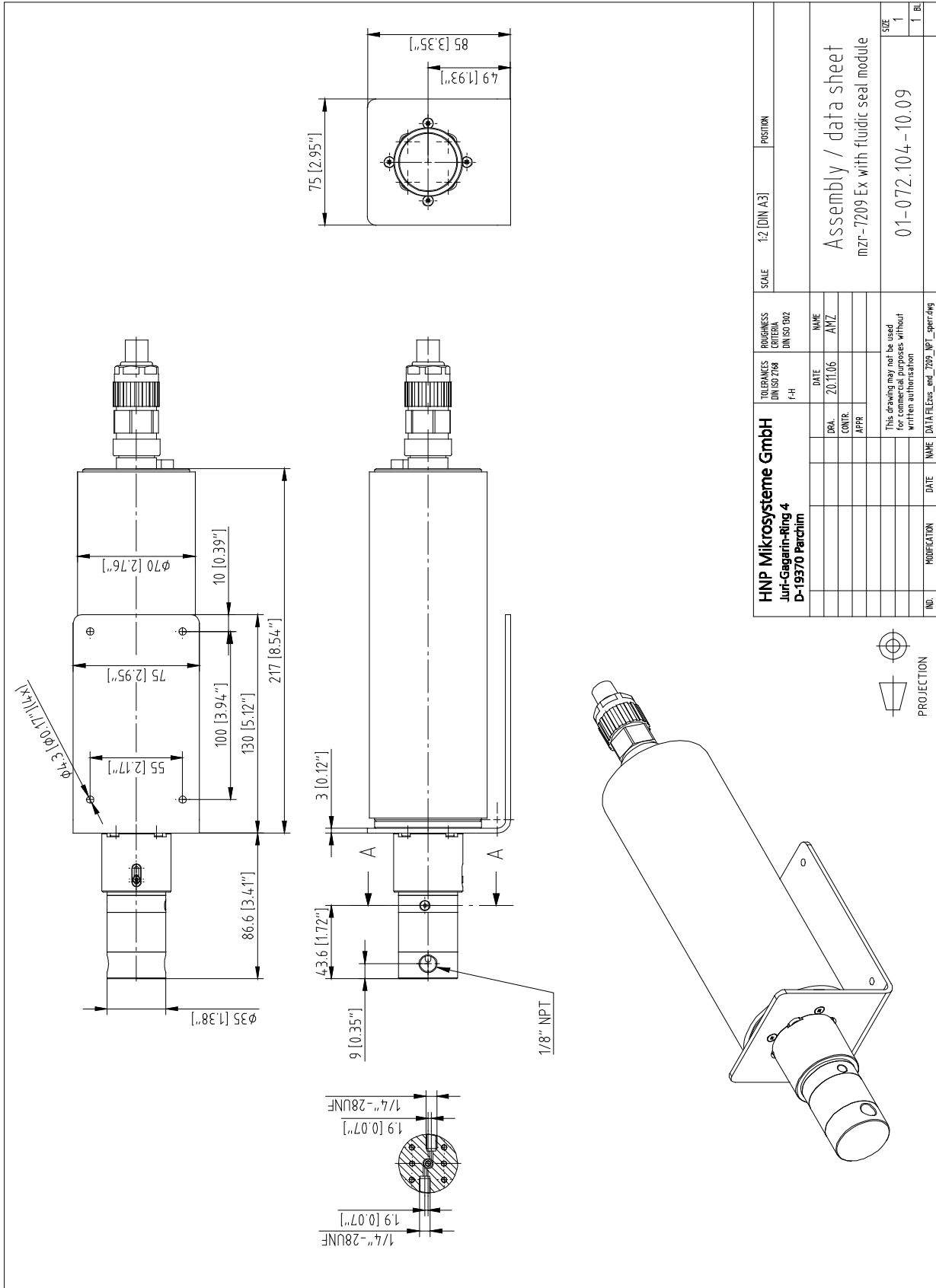

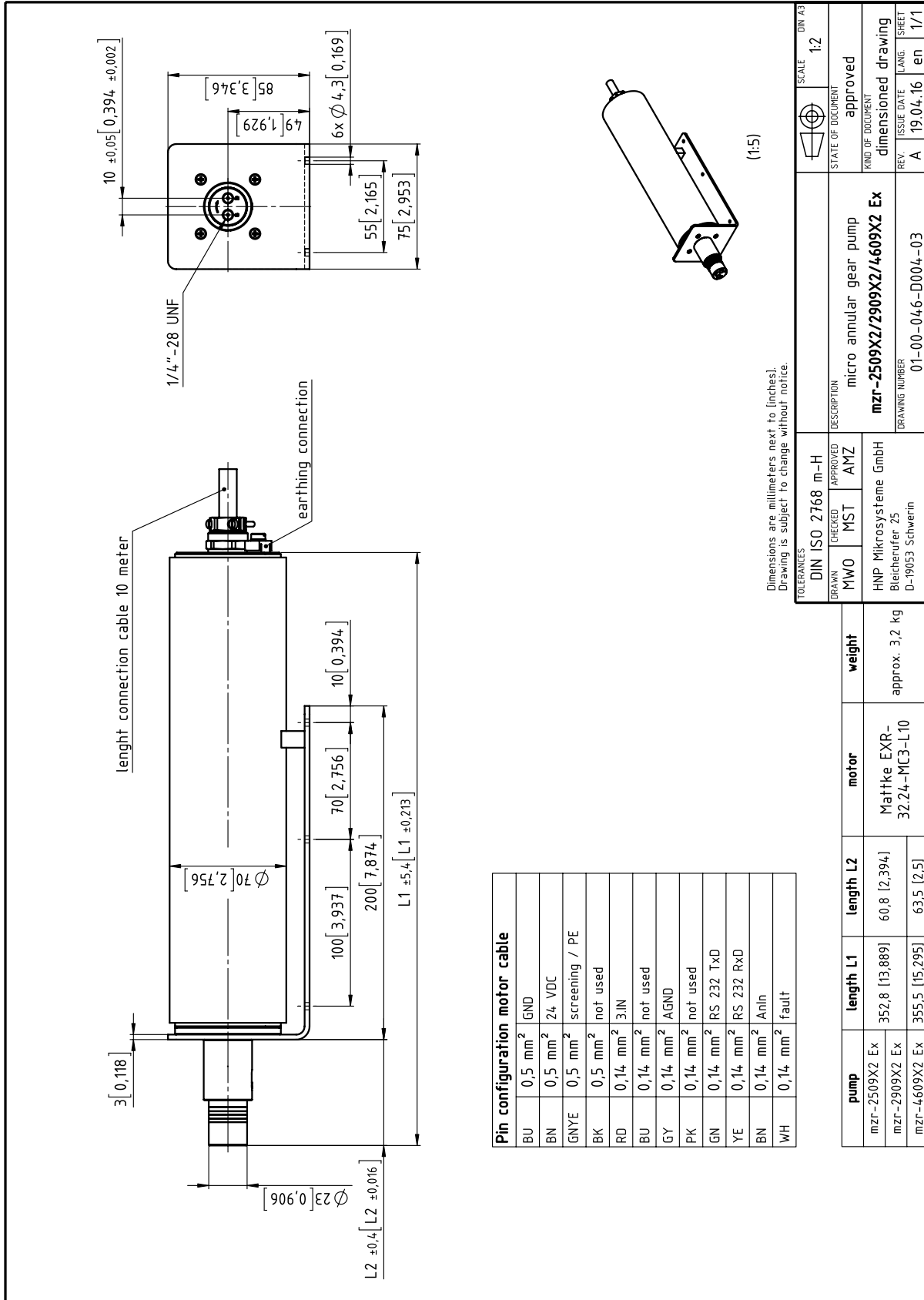

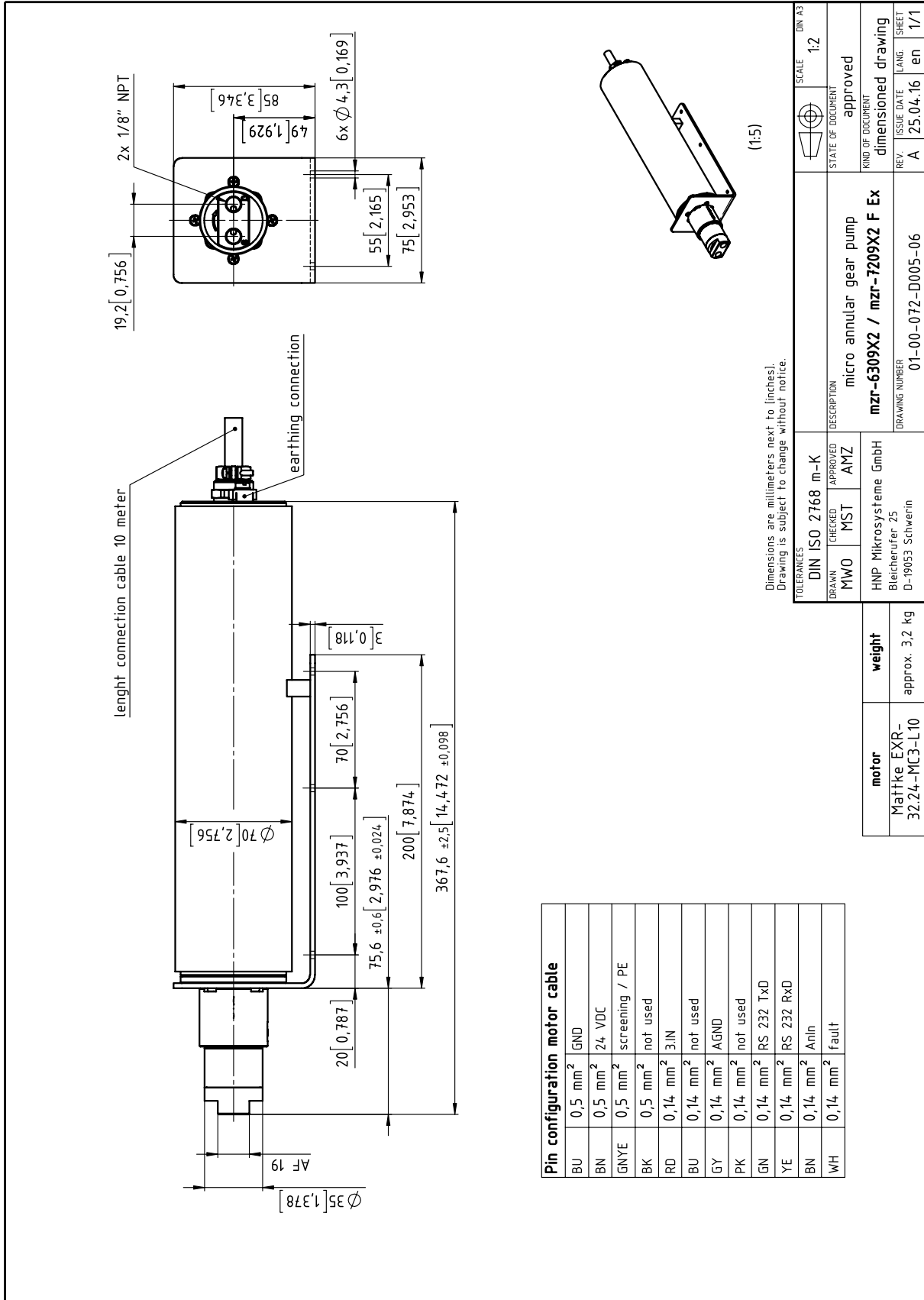

Pin configuration motor cable

BU	0,5 mm ²	GND
BN	0,5 mm ²	24 VDC
GNYE	0,5 mm ²	screening / PE
BK	0,5 mm ²	not used
RD	0,14 mm ²	3IN
BU	0,14 mm ²	not used
GY	0,14 mm ²	AGND
PK	0,14 mm ²	not used
GN	0,14 mm ²	RS 232 TxD
YE	0,14 mm ²	RS 232 RxD
BN	0,14 mm ²	Ain
WH	0,14 mm ²	fault

Dimensions are millimeters next to inches).
Drawing is subject to change without notice.

TOLERANCES		DIN ISO 2768 m-K	
DRAWN	CHECKED	APPROVED	SCALE
MWO	MST	AMZ	1:2
HNP Mikrosysteme GmbH		DESCRIPTION	
Bleichenrufer 25		micro annular gear pump	
D-19053 Schwerin		mzr-6309X2 / mzr-7209X2 F Ex	
DRAWING NUMBER		REV.	
01-00-072-D005-06		A	
DIN A3		STATE OF DOCUMENT	
1/1		approved	
LANG.		KIND OF DOCUMENT	
en		dimensioned drawing	
ISSUE DATE		REV.	
25.04.16		A	

motor	weight
Mattke EXR-32.24-MC3-L10	approx. 3.2 kg